



## State of New Jersey

DEPARTMENT OF ENVIRONMENTAL PROTECTION

401-02B

Bureau of Nonpoint Pollution Control

Division of Water Quality

Post Office Box 420

Trenton, New Jersey 08625-0420

609-633-7021 Fax: 609-777-0432

[http://www.state.nj.us/dep/dwq/bnpc\\_home.htm](http://www.state.nj.us/dep/dwq/bnpc_home.htm)

August 31, 2011

CHRIS CHRISTIE  
Governor

KIM GUADAGNO  
Lt. Governor

BOB MARTIN  
Commissioner

Judy Bruenjes, P.E.  
Hydro International  
94 Hutchins Dr.  
Portland, ME 04102-1930

Re: MTD Laboratory Test Certification for the Up-Flo Filter by Hydro International

**Effective Date: September 1, 2011**

**Expiration Date: September 1, 2013**

**TSS Removal Rate: 80%**

Dear Ms. Bruenjes:

The Stormwater Management Rules at N.J.A.C. 7:8 allow the use of manufactured treatment devices (MTDs) for compliance with the design and performance standards provided that the pollutant removal rates have been verified by New Jersey Corporation for Advanced Technology, NJCAT, and certified by the New Jersey Department of Environmental Protection (NJDEP).

The certification process was revised through the "Transition for Manufactured Treatment Devices," dated July 15, 2011. NJDEP has determined that Up-Flo Filter by Hydro International is consistent with the criteria under *A. Manufactured Treatment Devices with Interim Certifications*. Therefore, **NJDEP certifies the use of the Up-Flo Filter by Hydro International with an 80% TSS removal rate, provided that the project design is consistent with the following conditions:**

1. The various models and associated water quality flow capacities shall be sized for the peak flow of the New Jersey Water Quality Design Storm per N.J.A.C. 7:8-5.
2. The peak inflow of the Water Quality Design Storm is limited to 0.045 cfs per filter module. The maximum inflow area per filter module is limited to 0.3 acres of impervious area.

3. Sufficient draindown must be placed in any system to ensure that the draindown time for the Water Quality Design Storm does not exceed thirty-six (36) hours.
4. The Up-Flo Filter must provide a minimum of 2.8 cf of sediment storage volume for each filter module. If the Water Quality Design Storm is controlled by upstream detention / attenuation for 12 hours or more the minimum settling area does not apply.
5. The Up-Flo Filter is certified as an off-line system. Any flow above the New Jersey Water Quality Design Storm must be bypassed around the system.
6. This certification does not extend to the enhanced removal rates under N.J.A.C. 7:8 – 5.5 through the addition of settling chambers (such as hydrodynamic separators) or media filtration practices (such as a sand filter).
7. The maintenance plan for the sites using this device shall incorporate at a minimum, the maintenance requirements for the Up-Flo Filter shown attached.

In addition to the attached, any project with a Stormwater BMP subject to the Stormwater Management Rules, N.J.A.C. 7:8, must include a detailed maintenance plan. The detailed maintenance plan must include all of the items identified in Stormwater Management Rules, N.J.A.C. 7:8-5.8. Such items include, but are not limited to, the list of inspection and maintenance equipment and tools, specific corrective and preventative maintenance tasks, indication of problems in the system, and training of maintenance personnel. Additional information can be found in Chapter 8: Maintenance of the New Jersey Stormwater Best Management Manual.

NJDEP anticipates proposing further adjustments to this process through the readoption of the Stormwater Management Rules. Additional information regarding the implementation of the Stormwater Management Rules, N.J.A.C. 7:8, are available at [www.njstormwater.org](http://www.njstormwater.org). If you have any questions regarding the above information, please contact Ms. Sandra Blick of my office at (609) 633-7021.

Sincerely,



Ed Frankel, P.P., Acting Bureau Chief  
Bureau of Nonpoint Pollution Control

C: Richard S. Magee, NJCAT  
Chron file

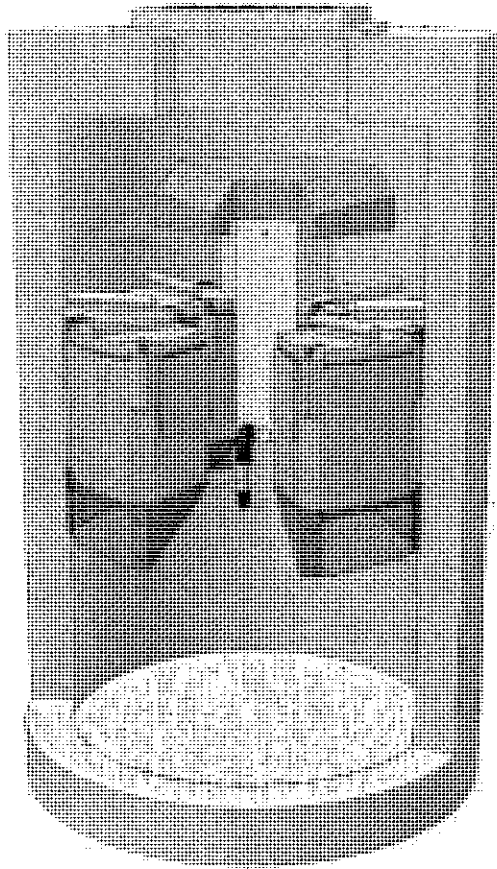

# The Up-Flo<sup>®</sup> Filter

---

Stormwater Treatment System

Operation and Maintenance Manual

---

## Table of Contents

3	Up-Flo® Filter <ul style="list-style-type: none"><li>- Overview</li><li>- General Product Description</li><li>- Typical Configurations</li><li>- Maintenance Services</li></ul>
4	Operation <ul style="list-style-type: none"><li>- Introduction</li><li>- Pollutant Capture</li><li>- Reduced Clogging</li><li>- Overflow Protection</li></ul>
5	Maintenance <ul style="list-style-type: none"><li>- Overview</li><li>- First-Year Monitoring</li><li>- Inspection</li><li>- Floatables, Oil and Sump Cleanout</li><li>- Replacement of Media Packs and Drain Down Filter</li></ul>
12	Up-Flo® Filter Installation Log
13	Up-Flo® Filter Inspection and Maintenance Log

### **IMPORTANT - ORDER REPLACEMENT PARTS FOR MAINTENANCE - IMPORTANT**

Annual maintenance requires replacement of the filter media packs and the Drain Down filter. Contact Hydro International to order replacements. Allow 2-4 weeks for delivery.

Office hours Monday thru Friday 8:00 A.M. to 5:00 P.M. EST  
Toll free: 1-800-848-2706  
Phone: 207-756-6200  
Fax: 207-756-6212

---

**COPYRIGHT STATEMENT:** The contents of this manual, including the drawings and specifications contained herein or annexed hereto, are intended for the use of the recipient to whom the document and all associated information are directed. Hydro International plc owns the copyright of this document (including any drawings or graphics); which is supplied in confidence. It must not be used for any purpose other than that for which it is supplied and must not be reproduced, in whole or in part stored in a retrieval system or transmitted in any form or by any means without prior permission in writing from Hydro International plc. Up-Flo® Filter is a trademarked filtration device of Hydro International plc. A patent covering the Up-Flo® Filter has been granted.

**DISCLAIMER:** Information and data contained in this manual is exclusively for the purpose of assisting in the operation and maintenance of Hydro International plc's Up-Flo® Filter. No warranty is given nor can liability be accepted for use of this information for any other purpose. Hydro International plc have a policy of continuous product development and reserve the right to amend specifications without notice.



## Product Overview

The Up-Flo® Filter is a modular high-rate stormwater filtration device. As shown below, it is typically installed into a 4-ft diameter catch basin structure. Each Filter Module has a screen and support bracket that is attached to the concrete manhole and each contains a Media Pack that includes flow distribution and filtration media. Modules can attach to each other to form a "ring" of up to six modules. Up to two of the modules are attached to an Outlet Module that has a Bypass Hood and filtered Drain Down. The modular design can be supplied in different configurations depending on the application as shown in the following illustrations.

An upward flow path through the Filter Modules allow stormwater to be screened and filtered. In addition to the screening and filtering processes, gross pollutants will also settle into the sump or float to the surface of the water held within the manhole. The standard units are supplied with a 3-ft sump to allow for sediment and gross pollutant accumulations between maintenance intervals.

The following manual describes the operation of the Up-Flo Filter and provides general maintenance requirements that will ensure the filter will continue to operate and perform as intended. In general, a minimum of two inspections are required the first year to monitor sediment and gross pollutant accumulations in the manhole structure and inspect the Filter

Media Pack and Drain Down Filter. The frequency of the maintenance interval is site specific as it will depend on the rate of pollutant accumulations. The first year of inspections and monitoring pollutant accumulations will determine future maintenance intervals.

Hydro International offers maintenance contracts nationwide, through Drainage Protections Systems (DPS). It is hoped that owners will take advantage of this service as operators of DPS have been trained and certified to ensure that maintenance will be performed properly. Should the owner choose to conduct maintenance procedures themselves, it is recommended that Hydro International be contacted to discuss the following procedures and consider contracting a representative from Hydro International for the first maintenance cycle.

Contact our Production Department

Office hours Monday thru Friday 8:00 A.M. to 5:00 P.M. EST

Toll free: 1-800-848-2706

Phone: 207-756-6200

Fax: 207-756-6212

### UP-FLO FILTER COMPONENTS

1. Inlet Grate
2. Bypass Siphon with Floatables Baffle
3. Filter Module
4. Outlet Module
5. Media Pack
6. Angled Screen
7. Drain Down Assembly (not visible)
8. Sump

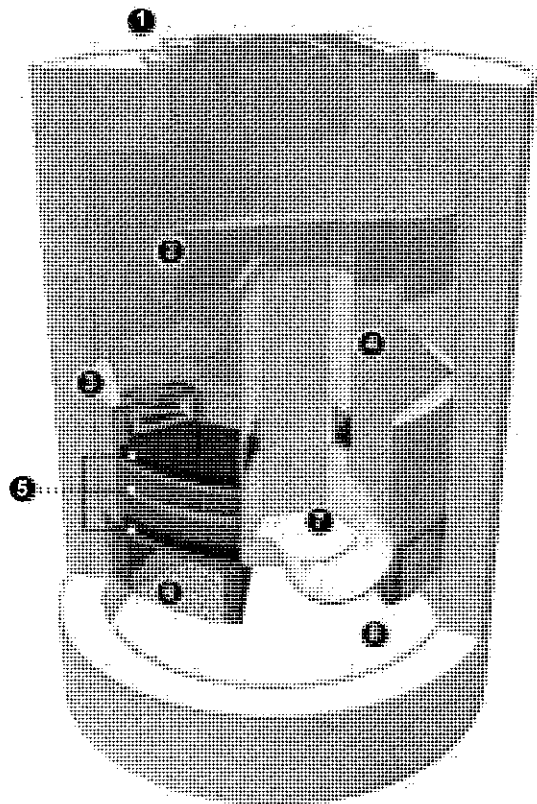

## Configurations

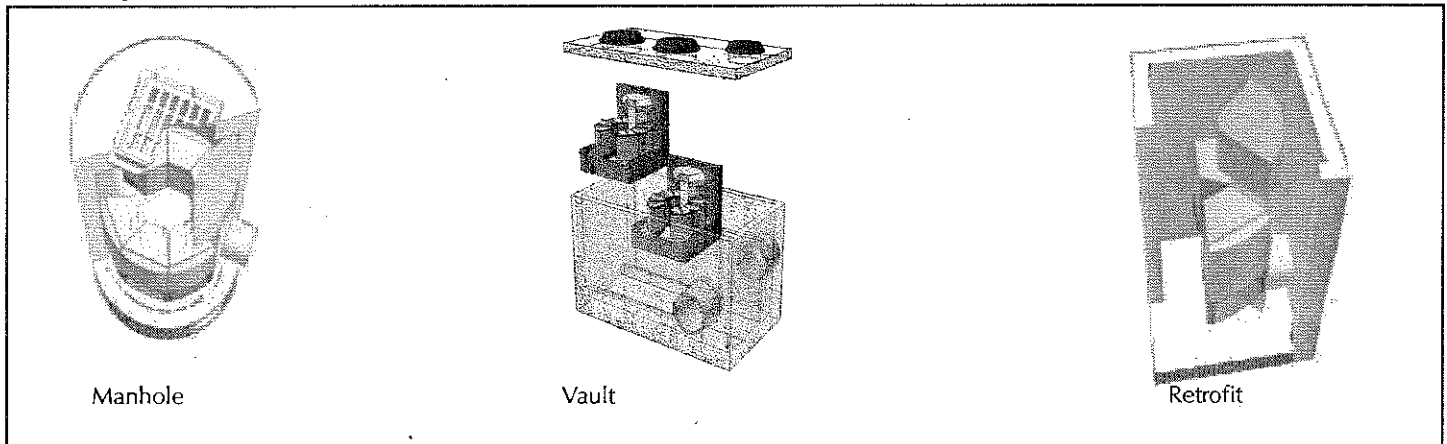

## Operation

### INTRODUCTION

The Up-Flo Filter operates on simple fluid hydraulics. It is self-activating, has no moving parts, no external power requirements and is fabricated with durable non-corrosive components. Personnel is not required to operate the unit and maintenance is limited to periodic inspections, sediment and floatables removal, Media Pack replacement and Drain Down Filter replacement.

### POLLUTANT CAPTURE

The Up-Flo Filter is designed to operate as a "treatment train" by incorporating multiple treatment technologies into a single device. Trash and gross debris are removed by sedimentation and screening before they are introduced to the filtration media, preventing surface blinding of the filter media. The Up-Flo Filter is a wet-sump device. Between storm events, oil and floatables are stored on the water surface separate from the sediment storage volume in the sump (see Figure 1). The high-capacity bypass siphon acts as a floatables baffle to prevent washout of captured floatable pollutants during high-intensity events.

### REDUCED CLOGGING

The Up-Flo Filter has been designed to minimize the occurrence of clogging and blinding. The Up-Flo Filter employs a unique Drain Down design that allows the water level in the chamber to drop below the filter media between events. The Drain Down mechanism creates a reverse flow that flushes captured pollutants off the surface of the filter bag, helping to prevent blinding. By allowing the water to drain out, the drain-down mechanism also reduces the weight of the filter bags. This makes the bags easier and safer to remove during maintenance operations.

### OVERFLOW PROTECTION

The Angled Screens are designed to prevent ragging and blinding. The Angled Screens are situated below the Filter Modules, sheltering them from the direct path of the influent. Coarse debris settles in the sump before the runoff flows up through the screens, protecting them from blinding. In the unlikely event of a blockage, the high capacity Siphonic Bypass is designed to convey high enough flow that large storm events will not create upstream flooding.

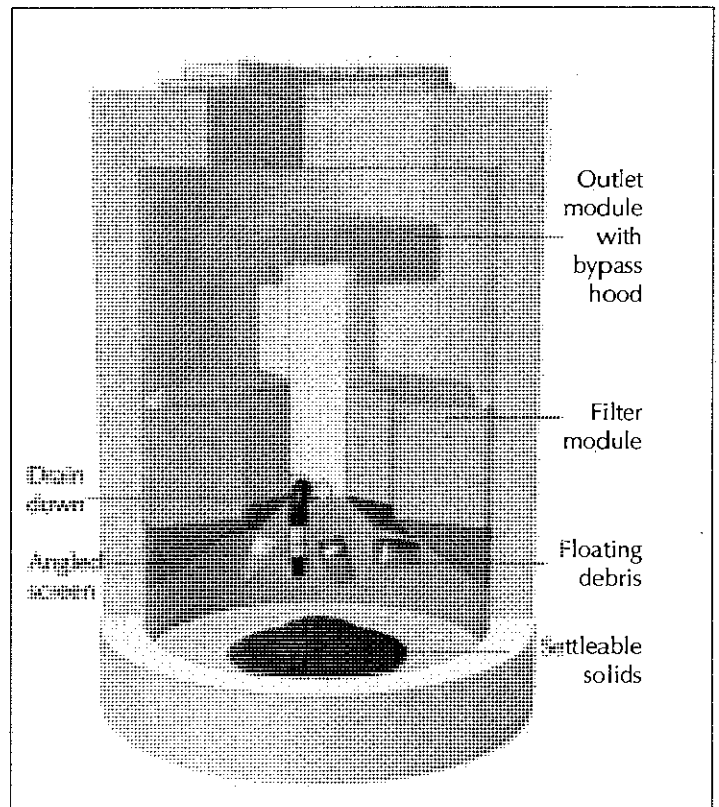

Figure 1: Pollutants captured in the Up-Flo Filter

## Maintenance

### OVERVIEW

The Up-Flo Filter protects the environment by removing a wide range of pollutants from stormwater runoff. Periodic removal of these captured pollutants is essential to the proper functioning of the Up-Flo Filter.

The Up-Flo Filter design allows for easy and safe inspection, monitoring and clean-out procedures. It has a wide central opening between the Filter Modules for easy and comfortable access to all of the components (See figure 2). Completion of all the maintenance activities for a typical manhole Up-Flo Filter takes less than one hour.

Maintenance activities include inspection, floatables removal, oil removal, sediment removal, Media Pack replacement, and Drain Down Filter replacement. Maintenance intervals are determined from monitoring the Up-Flo Filter during its first year of operation. Depending on the site, some maintenance activities may have to be performed on a more frequent basis than others. In the case of inspection and floatables removal, a vactor truck is not required. Otherwise, a vactor truck is normally required for oil removal, removal of sediment from the sump, and replacement of the Media Packs and Drain Down Filter. In most cases, entry into the Up-Flo Filter vessel is required for replacement of the Media Packs and Drain Down Filter, and OSHA Confined Space Entry procedures will have to be followed.

Media Packs should not be installed in the modules until construction activities are complete and site stabilization is effective.

### FIRST-YEAR MONITORING

Hydro International recommends that inspections be performed at least every six months during the first year of operation. Use the following guidelines for determining maintenance intervals:

- **Floatables and Oil Monitoring:** The water surface in the Up-Flo Filter should be monitored for accumulation of floatables and oil. Floatables should not be allowed to accumulate to the point where they completely cover the surface of the water. Oil should not be allowed to accumulate to the point where it has formed a measurable thickness on the surface of the water. The rate of floatables and oil accumulation can be estimated by dividing the surface area covered by floatables and/or oil by the number of months since the Up-Flo Filter was installed.
- **Sediment Monitoring:** A simple probe, such as the Sludge-Judge®, should be used to determine the depth of sediment

in the sump. The maximum allowable sediment depth in a typical 4-foot diameter manhole equipped with an Up-Flo Filter is 16". In any case, sediment must be removed before it blocks the inlet to the Drain Down Filter. The rate of sediment accumulation can be estimated by dividing the measured depth of sediment by the number of months since the Up-Flo Filter was installed.

- **Media Pack Monitoring:** Filter bags should be weighed to determine the amount of particles that have been captured in the bags. Filter bags from one or two modules should be weighed. Spent filter bags weigh approximately 40 lbs wet. The rate of filter bag clogging can be estimated by subtracting the wet weight of a new bag (approximately 20 lbs.) from the measured wet weight of the bags being checked and dividing by the number of months since the bags were installed.
- **Drain Down Filter Monitoring:** The water level in the Up-Flo Filter should be monitored to ensure that the Drain Down Filter is operating properly. One to two days after a significant rainfall, the water level inside the vessel should have dropped to a point where it is equal with the base of the Filter Modules. If the water level has not reached that point, then the Drain Down Filter has either become clogged or blinded by trash or debris. If there is no evidence of trash or debris around the Drain Down Filter inlet, then it has likely become clogged with particles. The rate of Drain Down Filter clogging can be estimated by noting the number of months since the Up-Flo Filter was installed.

Hydro International recommends a maximum maintenance interval of one year for all maintenance activities but, based on the first-year monitoring,

a shorter maintenance interval for some maintenance activities may be appropriate.

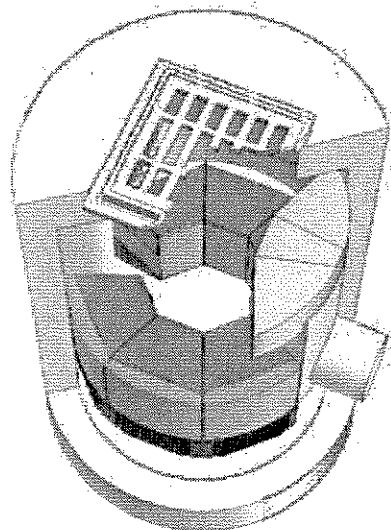

**Figure 2:** The wide central opening in the Up-Flo Filter

## INSPECTION

Inspection is a simple process that requires monitoring pollutant accumulations. Maintenance crews should be familiar with the Up-Flo Filter and its components prior to inspection.

### SCHEDULING

- Inspection may be conducted during any season of the year but should occur shortly after a predicted rainfall to ensure components are operating properly.

### RECOMMENDED EQUIPMENT

- Safety Equipment and Personal Protective Equipment (traffic cones, work gloves, etc.)
- Scale to measure the weight of the filter bags
- Crow bar to remove grate or lid
- Pole with skimmer or net
- Sediment probe (such as a Sludge Judge®)
- Hydro International Up-Flo Filter Maintenance Log
- Trash bags for removed floatables

### INSPECTION PROCEDURES

1. Set up any necessary safety equipment (such as traffic cones) to provide access to the Up-Flo® Filter. Safety equipment should notify passing pedestrian and road traffic that work is being done.
2. Remove the grate or lid to the manhole or vault.
3. Without entering the vessel, look down into the chamber to inspect the inside. Make note of any irregularities. See Figure 3 for a typical Inspection View.
4. Without entering the vessel, use the pole with the skimmer net to remove floatables and loose debris from the chamber.
5. Using a sediment probe such as a Sludge Judge®, measure the depth of sediment that has collected in the sump of the vessel. Maximum sediment depth is 16 inches.
6. Remove the Filter Module lid by turning the cam latch and remove the Filter Media Pack (refer to page 8 Replacement Procedures). Weigh the filter bags from one or two modules. Filter bags should be replaced if the wet weight exceeds 40 lbs.
7. On the Maintenance Log provided by Hydro International, record the date, unit location, estimated volume of floatables and gross debris removed, and the depth of sediment measured. Also note any apparent irregularities such as damaged components or a high standing water level (see Figure 3 for the standard standing water level).
8. Securely replace the grate or lid.
9. Remove safety equipment.
10. Contact Hydro International at 1-800-848-2706 to discuss any irregularities noted during inspection.

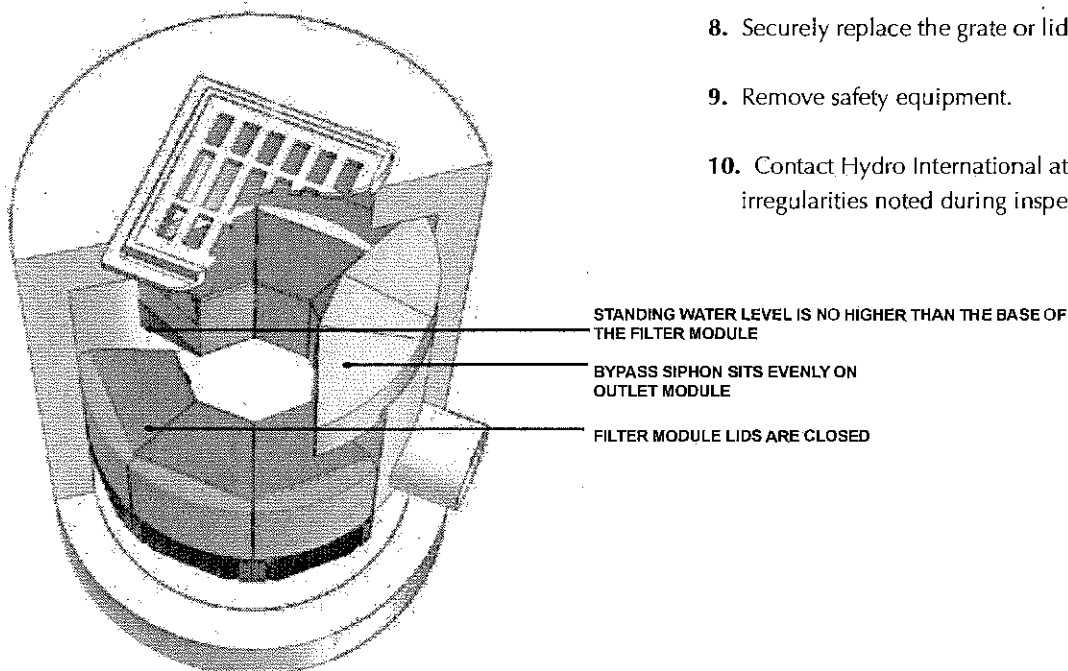

Figure 3: Inspection view of the Up-Flo Filter



## FLOATABLES, OIL, AND SUMP CLEANOUT

A commercially or municipally owned sump-vac is used to remove captured sediment, oil and floatables (Figure 4).

Floatables and loose debris can also be netted with a skimmer and pole. The access port located at the top of the manhole provides unobstructed access for a vactor hose and skimmer pole to be lowered to the base of the sump.

### SCHEDULING

- Floatables and sump cleanout may typically be done during any season of the year - before and after rainy season
- Floatables and sump cleanout should occur as soon as possible following a contaminated spill in the contributing drainage area

### RECOMMENDED EQUIPMENT

- Safety Equipment (traffic cones, etc)
- Crow bar to remove grate or lid
- Pole with skimmer or net (if only floatables are being removed)
- Sediment probe (such as a Sludge Judge®)
- Vactor truck (flexible hose preferred)
- Pressure nozzle attachment or other screen-cleaning device
- Hydro International Up-Flo Filter Maintenance Log

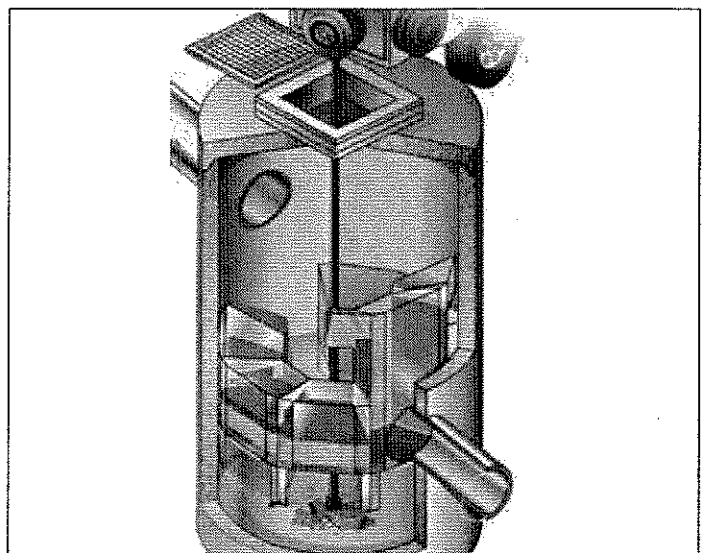

Figure 4: Sediment is removed with a vactor hose

**FLOATABLES, OIL AND SUMP CLEAN OUT PROCEDURES**

1. Set up any necessary safety equipment (such as traffic cones) around the access of the Up-Flo Filter. Safety equipment should notify passing pedestrian and road traffic that work is being done.
2. Remove the grate or lid to the manhole or vault.
3. Without entering the vessel, look down into the chamber to inspect the inside. Make note of any irregularities.
4. If the standing water level in the sump is above the base of the Filter Modules (see Figure 3), tug the Pull Chain(s) to release the Drain Down Plug(s). Allow the excess water to drain out of the chamber.
5. Use the skimmer pole to fit the Drain Down plug back into the open port.
6. Once all floatables and oil have been removed, drop the vactor hose to the base of the sump. Vactor out the sediment and gross debris from the sump floor. Up to 0.6 yd<sup>3</sup> of sediment and 360 gallons of water will be removed from a typical manhole Up-Flo Filter during this process.
7. Retract the vactor hose from the vessel.
8. Inspect the Angled Screens for blockages and ragging. If present, remove the obstruction or ragging materials from the surface using a hose or other screen-cleaning device.
9. On the Maintenance Log provided by Hydro International, record the date, unit location, estimated volume of floatables, oils, and gross debris removed, and the depth of sediment measured. Note any apparent irregularities such as damaged components or blockages.
10. Securely replace the grate or lid.
11. Remove safety equipment.
12. Dispose of sediment and gross debris at your local landfill; following local regulations.
13. Dispose of oil and sump water at a licensed water treatment facility.

14. Contact Hydro International at 1-800-848-2706 to discuss any irregularities noted during cleanout.

**REPLACEMENT OF MEDIA PACKS AND DRAIN DOWN FILTER**

Unless the Up-Flo Filter has been installed as a very shallow unit, it is necessary to have an OSHA-confined space entry trained person enter the vessel to replace Media Packs.

**SCHEDULING**

- Call Hydro International to order replacement Media Packs and Drain Down filter prior to scheduling maintenance.
- Because Media Pack replacement requires entry into the Up-Flo chamber, maintenance events should be scheduled during dry weather.
- Media Pack replacement should occur immediately after a contaminated spill in the contributing drainage area.

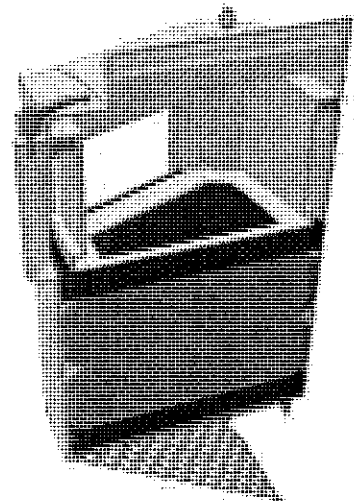

**Figure 5:** Cut-away view of the Filter Module

**RECOMMENDED EQUIPMENT**

- Safety Equipment (traffic cones, etc)
- Crow bar to remove grate or lid
- Pole with skimmer or net (if floatables removal is not to be done with vacor hose)
- Sediment probe (such as a Sludge Judge®)
- Vacor truck (flexible hose preferred)
- OSHA Confined Space Entry Equipment
- Up-Flo Filter Replacement Media Packs (available from Hydro International)
- Hydro International Up-Flo Filter Maintenance Log
- Screwdriver (flat head)
- Replacement Drain Down Filter components supplied by Hydro International

**MEDIA PACK AND DRAIN DOWN FILTER REPLACEMENT PROCEDURES**

1. Follow Floatables and Sump Cleanout Procedures, 1 – 10.
2. Following OSHA Confined Space Entry procedures, enter the Up-Flo Filter Chamber.
3. Open the Filter Module by turning the three cam latches on the front and sides of the module. Remove the lid ① to gain access to the Media Pack (Figure 6).
4. Remove and discard the spent **Media Pack**. The **Media Pack** contents include:
  - A top layer of green ② Flow-Distributing Media.
  - Two (2) Media Bags ③ equipped with nylon handles.
  - A bottom layer of green ② Flow-Distributing Media.

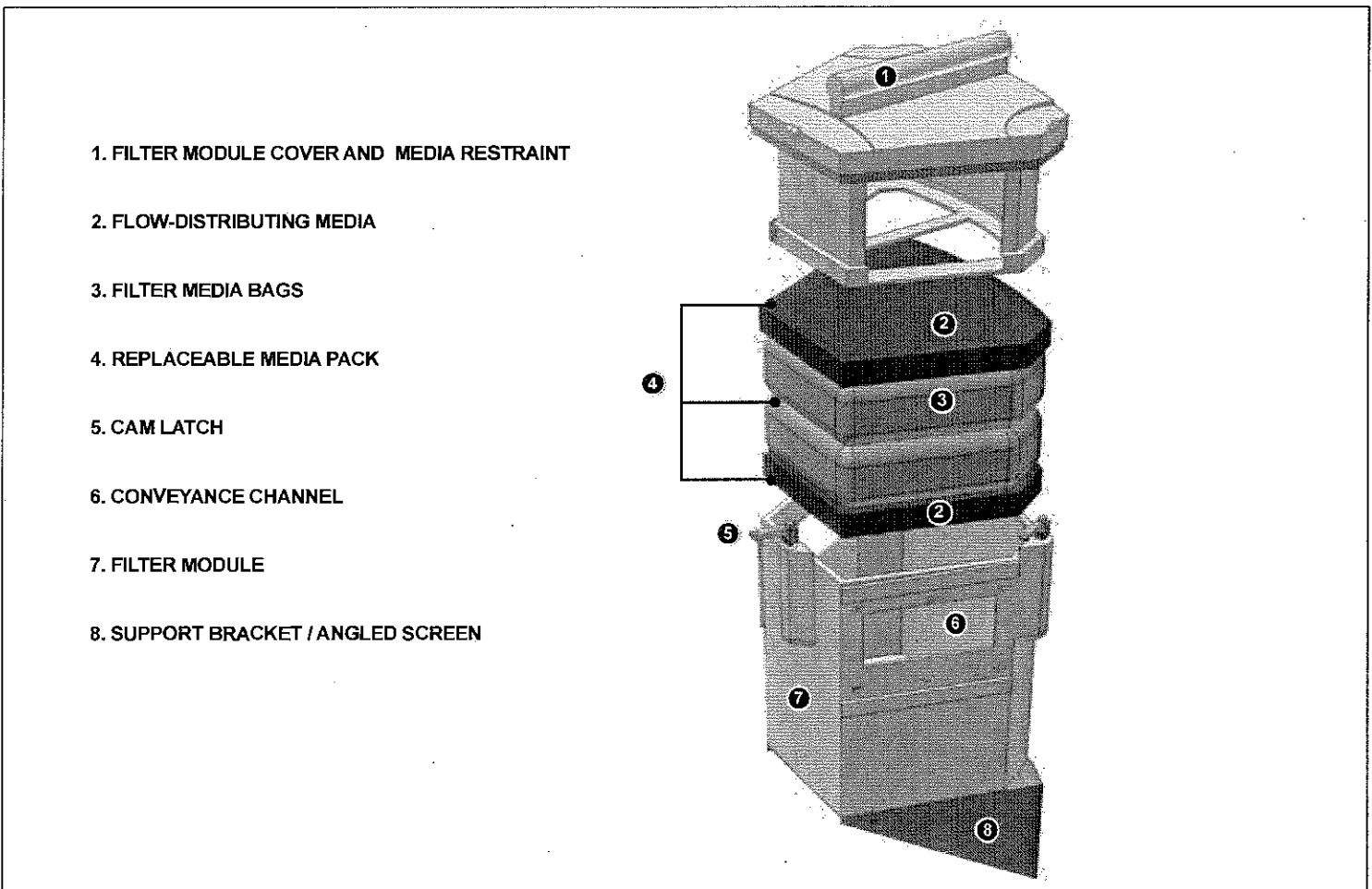

**Figure 6:** The Filter Module houses the Media Restraint and the Media Pack

5. Insert a new Media Pack, supplied by Hydro International.
  - First, insert a bottom layer of green **Flow-Distributing Media**. Be sure that the media sits snugly and level at the bottom of the Filter Module.
  - Next, insert the first of two (2) replacement **Media Bags**. Smooth the bag out with your hands to make sure that the bag extends snugly to the walls and corners of the Filter Module.
  - Insert the second **Media Bag**, following the same procedure.
  - Insert the top layer of green **Flow-Distributing Media**. Be sure that the piece fits snugly against the walls and corners of the Filter Module.
  - Put the lid on and secure the three latches. Check to make sure that the latches are closed properly.
6. Use a screwdriver to unscrew the **Drain Down Filter** from the face of the Outlet Module (see Figure 7). **DO NOT DISCARD THIS PIECE.**
7. Install new **Drain Down Filter** supplied by Hydro International.
8. Exit the Up-Flo Filter chamber and securely replace the grate or lid.

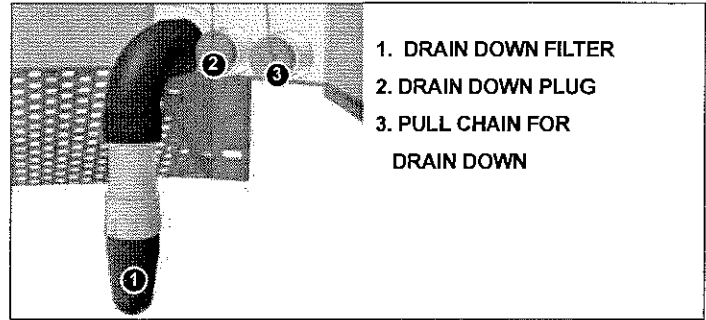

Figure 7: The Drain Down Filter

1. DRAIN DOWN FILTER
2. DRAIN DOWN PLUG
3. PULL CHAIN FOR DRAIN DOWN

9. On the Maintenance Log provided by Hydro International, record the date, unit location, estimated volume of floatables, oil and gross debris removed, and the depth of sediment measured. Note the number of Media Packs replaced. Note any irregularities such as damaged components or blockages.
10. Remove safety equipment.
11. Dispose of spent media packs at your local landfill, following local regulations.
12. Return the spent Drain Down Filter to Hydro International.
13. Contact Hydro International to discuss any irregularities noted during annual maintenance.

## Maintenance at a Glance

ACTIVITY	FREQUENCY
Inspection	- Regularly during first year of installation - Every 6 months after the first year of installation
Floatables/Oils Removal	- Twice per year or as needed - Following a contaminated spill in the drainage area
Sediment Removal	- Twice per year or as needed - Following a contaminated spill in the drainage area
Media Pack Replacement	- Once per year or as needed - Following a contaminated spill in the drainage area
Drain Down Filter Replacement	- Once per year with Media Pack replacement - As needed, in the event of continuous base flow conditions

# UP-FLO® FILTER

## INSPECTION & MAINTENANCE LOG

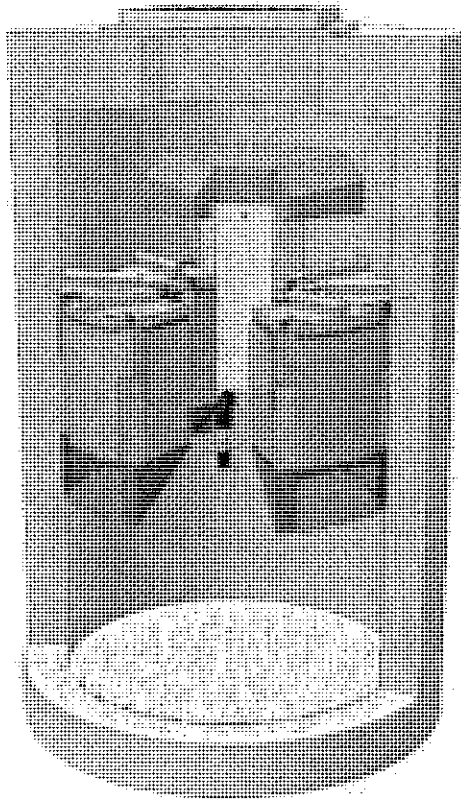



## Up-Flo® Filter Installation Log

HYDRO INTERNATIONAL REFERENCE NUMBER:	
SITE NAME:	
SITE LOCATION:	
OWNER:	CONTRACTOR:
CONTACT NAME:	CONTACT NAME:
COMPANY NAME:	COMPANY NAME:
ADDRESS:	ADDRESS:
TELEPHONE:	TELEPHONE:
FAX:	FAX:

INSTALLATION DATE:    /    /

CONFIGURATION (CIRCLE ONE):    MANHOLE                      RETROFIT                      VAULT SYSTEM

TOTAL NUMBER OF UP-FLO™ FILTER MODULES:



# Hydro International

[www.hydro-international.biz](http://www.hydro-international.biz)

## United Kingdom

Shearwater House • Clevedon Hall Estate  
Victoria Road • Clevedon, BS21 7RD  
Tel: +44 (0) 1275 878371  
Fax: +44 (0) 1275 874979

## United States

94 Hutchins Drive  
Portland, ME 04102  
Tel: 207 756 6200  
Fax: 207 756 6212

## Ireland

Tootenhill House  
Rathcoole • Co Dublin  
Tel: +353 (0)1 4013964  
Fax: +353 (0)1 4013978

