

NJCAT Technology Verification and NJDEP Approval

Section F



State of New Jersey

DEPARTMENT OF ENVIRONMENTAL PROTECTION

Bureau of Nonpoint Pollution Control

Division of Water Quality

401-02B

Post Office Box 420

Trenton, New Jersey 08625-0420

609-633-7021 Fax: 609-777-0432

http://www.state.nj.us/dep/dwq/bnpc_home.htm

KIM GUADAGNO

CHRIS CHRISTIE

Governor

Lt. Governor

BOB MARTIN

Commissioner

December 21, 2017

Zachariha J. Kent
Director of Research & Development
BioClean Environmental Services, Inc.
P O Box 869
Oceanside, CA 92049

Re: MTD Lab Certification
SciClone™ Hydrodynamic Separator by BioClean Environmental Services, Inc.
On-line Installation

TSS Removal Rate 50%

Dear Mr. Kent:

The Stormwater Management rules under N.J.A.C. 7:8-5.5(b) and 5.7 (c) allow the use of manufactured treatment devices (MTDs) for compliance with the design and performance standards at N.J.A.C. 7:8-5 if the pollutant removal rates have been verified by the New Jersey Corporation for Advanced Technology (NJCAT) and have been certified by the New Jersey Department of Environmental Protection (NJDEP). BioClean Environmental Services, Inc. has requested an MTD Laboratory Certification for the SciClone™ Hydrodynamic Separator (SciClone).

The project falls under the "Procedure for Obtaining Verification of a Stormwater Manufactured Treatment Device from New Jersey Corporation for Advance Technology" dated January 25, 2013. The applicable protocol is the "New Jersey Laboratory Testing Protocol to Assess Total Suspended Solids Removal by a Hydrodynamic Sedimentation Manufactured Treatment Device" dated January 25, 2013.

NJCAT verification documents submitted to the NJDEP indicate that the requirements of the aforementioned protocol have been met or exceeded. The NJCAT letter also included a recommended certification TSS removal rate and the required maintenance plan. The NJCAT Verification Report with the Verification Appendix (dated December 2017) for this device is published online at <http://www.njcat.org/verification-process/technology-verification-database.html>.

The NJDEP certifies the use of the SciClone by BioClean Environmental Services, Inc. at a TSS removal rate of 50% when designed, operated, and maintained in accordance with the information provided in the Verification Appendix and the following conditions:

1. The maximum treatment flow rate (MTFR) for the manufactured treatment device (MTD) is calculated using the New Jersey Water Quality Design Storm (1.25 inches in 2 hrs) in N.J.A.C. 7:8-5.5.
2. The SciClone shall be installed using the same configuration reviewed by NJCAT and shall be sized in accordance with the criteria specified in item 6 below.
3. This SciClone cannot be used in series with another MTD or a media filter (such as a sand filter) to achieve an enhanced removal rate for total suspended solids (TSS) removal under N.J.A.C. 7:8-5.5.
4. Additional design criteria for MTDs can be found in Chapter 9.6 of the New Jersey Stormwater Best Management Practices (NJ Stormwater BMP) Manual, which can be found online at www.njstormwater.org.
5. The maintenance plan for a site using this device shall incorporate, at a minimum, the maintenance requirements for the SciClone. A copy of the maintenance plan is attached to this certification. However, it is recommended to review the maintenance website at <http://www.biocleanenvironmental.com/wp-content/uploads/2017/07/Operations-Maintenance-SciClone-1.pdf> for any changes to the maintenance requirements.
6. Sizing Requirement:

The example below demonstrates the sizing procedure for the SciClone:

Example: A 0.25-acre impervious site is to be treated to 50% TSS removal using a SciClone. The impervious site runoff (Q) based on the New Jersey Water Quality Design Storm was determined to be 0.79 cfs.

Maximum Treatment Flow Rate (MTFR) Evaluation:

The site runoff (Q) was based on the following:

time of concentration = 10 minutes

i = 3.2 in/hr (page 5-8, Fig. 5-3 of the NJ Stormwater BMP Manual)

c = 0.99 (runoff coefficient for impervious)

$Q = ciA = 0.99 \times 3.2 \times 0.25 = 0.79$ cfs

Given the site runoff is 0.79 cfs and based on Table 1 below, the SciClone Model SC-5 with a MTFR of 1.09 cfs could be used for this site to remove 50% of the TSS from the impervious area without exceeding the MTFR.

The sizing table corresponding to the available system models is noted below. Additional specifications regarding each model can be found in the Verification Appendix under Tables A-1 and A-2.

Table 1 SciClone Sizing Information

SciClone Model	Maximum Treatment Flow Rate (cfs)	Treatment Area (ft²)	Hydraulic Loading Rate (gpm/ft²)	50% Maximum Sediment Storage (ft³)
SC-3	0.39	7.1	25	5.3
SC-4	0.70	12.6	25	9.4
SC-5	1.09	19.6	25	14.7
SC-6	1.57	28.3	25	21.2
SC-7	2.14	38.5	25	28.9
SC-8	2.80	50.2	25	37.7
SC-9	3.54	63.6	25	47.7
SC-10	4.37	78.5	25	58.9
SC-11	5.29	95.0	25	71.2
SC-12	6.30	113.0	25	84.8
SC-13	7.39	132.7	25	99.5
SC-14	8.57	153.9	25	115.4

A detailed maintenance plan is mandatory for any project with a Stormwater BMP subject to the Stormwater Management Rules, N.J.A.C. 7:8. The plan must include all of the items identified in the Stormwater Management Rules, N.J.A.C. 7:8-5.8. Such items include, but are not limited to, the list of inspection and maintenance equipment and tools, specific corrective and preventative maintenance tasks, indication of problems in the system, and training of maintenance personnel. Additional information can be found in Chapter 8: Maintenance and Retrofit of Stormwater Management Measures.

If you have any questions regarding the above information, please contact Mr. Shashi Nayak of my office at (609) 633-7021.

Sincerely,

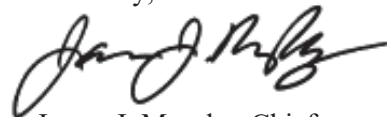

James J. Murphy, Chief
Bureau of Nonpoint Pollution Control

Attachment: Maintenance Plan

cc: Chron File
Richard Magee, NJCAT
Vince Mazzei, NJDEP - DLUR
Ravi Patraju, NJDEP - BES
Gabriel Mahon, NJDEP - BNPC
Shashi Nayak, NJDEP - BNPC

NJCAT TECHNOLOGY VERIFICATION

SciClone™ Hydrodynamic Separator

Bio Clean Environmental Services, Inc.

December 2017

Table of Contents

List of Figures.....	ii
List of Tables.....	iii
1. Description of Technology.....	1
2. Laboratory Testing.....	3
2.1 Test Setup.....	4
2.2 Test Sediment.....	6
2.3 Removal Efficiency Testing.....	9
2.4 Scour Testing.....	9
3. Performance Claims.....	10
4. Supporting Documentation.....	11
4.1 Removal Efficiency Testing.....	11
4.2 Scour Testing.....	22
5. Design Limitations.....	24
6. Maintenance Plans.....	26
7. Statements.....	29
8. References.....	34
Verification Appendix.....	35

List of Figures

Figure 1 Cut-Away View.....	1
Figure 2 Operational Diagram.....	2
Figure 3 Effective Treatment Area and Flow Path Diagram.....	2
Figure 4 View During Treatment and Bypass Flows.....	3
Figure 5 Test Flow Apparatus.....	4
Figure 6 Background Sampling Point.....	6
Figure 7 Effluent Sampling Point.....	6
Figure 8 Sediment Addition Point.....	7
Figure 9 Average Particle Size Distribution of Removal Efficiency Test Sediment.....	8
Figure 10 Particle Size Distribution of Scour Test Sediment.....	9
Figure 11 Water Flow and Temperature - 25% MTFR.....	13
Figure 12 Water Flow and Temperature - 50% MTFR.....	15
Figure 13 Water Flow and Temperature - 75% MTFR.....	17
Figure 14 Water Flow and Temperature - 100% MTFR.....	19
Figure 15 Water Flow and Temperature - 125% MTFR.....	21
Figure 16 Water Flow and Temperature - Scour Test.....	23

List of Tables

Table 1 SciClone™ Model SC-4 Dimensions.....	4
Table 2 PSD of Removal Efficiency Test Sediment (Lot # A016-042).....	7
Table 3 PSD of Scour Test Sediment (Lot # A017-001).....	8
Table 4 Sampling Schedule - 25% MTFR.....	12
Table 5 Water Flow and Temperature - 25% MTFR.....	12
Table 6 Sediment Feed Rate Summary – 25% MTFR.....	13
Table 7 SSC and Removal Efficiency - 25% MTFR.....	14
Table 8 Sampling Schedule - 50% MTFR.....	14
Table 9 Water Flow and Temperature - 50% MTFR.....	15
Table 10 Sediment Feed Rate Summary – 50% MTFR.....	15
Table 11 SSC and Removal Efficiency - 50% MTFR.....	16
Table 12 Sampling Schedule - 75% MTFR.....	16
Table 13 Water Flow and Temperature - 75% MTFR.....	17
Table 14 Sediment Feed Rate Summary – 75% MTFR.....	17
Table 15 SSC and Removal Efficiency - 75% MTFR.....	18
Table 16 Sampling Schedule - 100% MTFR.....	18
Table 17 Water Flow and Temperature - 100% MTFR.....	19
Table 18 Sediment Feed Rate Summary – 100% MTFR.....	19
Table 19 SSC and Removal Efficiency - 100% MTFR.....	20
Table 20 Sampling Schedule - 125% MTFR.....	20
Table 21 Water Flow and Temperature - 125% MTFR.....	21
Table 22 Sediment Feed Rate Summary – 125% MTFR.....	21
Table 23 SSC and Removal Efficiency - 125% MTFR.....	22
Table 24 Annualized Weighted Removal Efficiency for SciClone™.....	22

Table 25 Scour Test Sampling Frequency.....23

Table 26 Water Flow and Temperature - Scour Test.....23

Table 27 Suspended Sediment Concentrations for Scour Test.....24

Table A-1 MTFRs and Sediment Removal Intervals for SciClone™ Models.....37

Table A-2 Standard Dimensions for Bio Clean SciClone™ Models.....38

1. Description of Technology

The SciClone™ hydrodynamic separator (SciClone™) is a manufactured treatment device (MTD) designed by Bio Clean Environmental Services, Inc. The SciClone™ removes pollutants from stormwater runoff using a series of flow splitters, weirs and baffles. The device traps suspended particulates by promoting gravity separation, as well as being able to capture and retain floatables and light liquids, such as oil.

The SciClone™ is designed to maximize the flow path of entering stormwater thus optimizing its ability to capture suspended solids efficiently with minimal surface area. The system has no moving parts and operates utilizing the principles of gravity separation and flow path maximization to increase settling of finer particulates. It is composed of three components as shown in **Figure 1**.

Runoff is directed into the system via the inflow pipe and enters the flow splitter deck, as illustrated in **Figure 2**. From the flow splitter, water is channeled along the chamber wall on both sides of the inlet pipe. This splitting of the flow reduces inlet velocity into the system and channels flow along the walls of the chamber. As the split flow comes into contact with the oil/floatables skimmer wall, it is directed along the skimmer wall toward the center of the chamber. At the center of the chamber the flow paths from both sides meet one another. As this occurs the flow path from both directions circles back toward the inlet pipe. This configuration directs the flow back toward the inlet and underneath the flow splitter deck thus maximizing the flow path. Finer sediments are directed into the sump chamber below the flow splitter to the chamber wall under the inlet as shown in **Figure 3**.

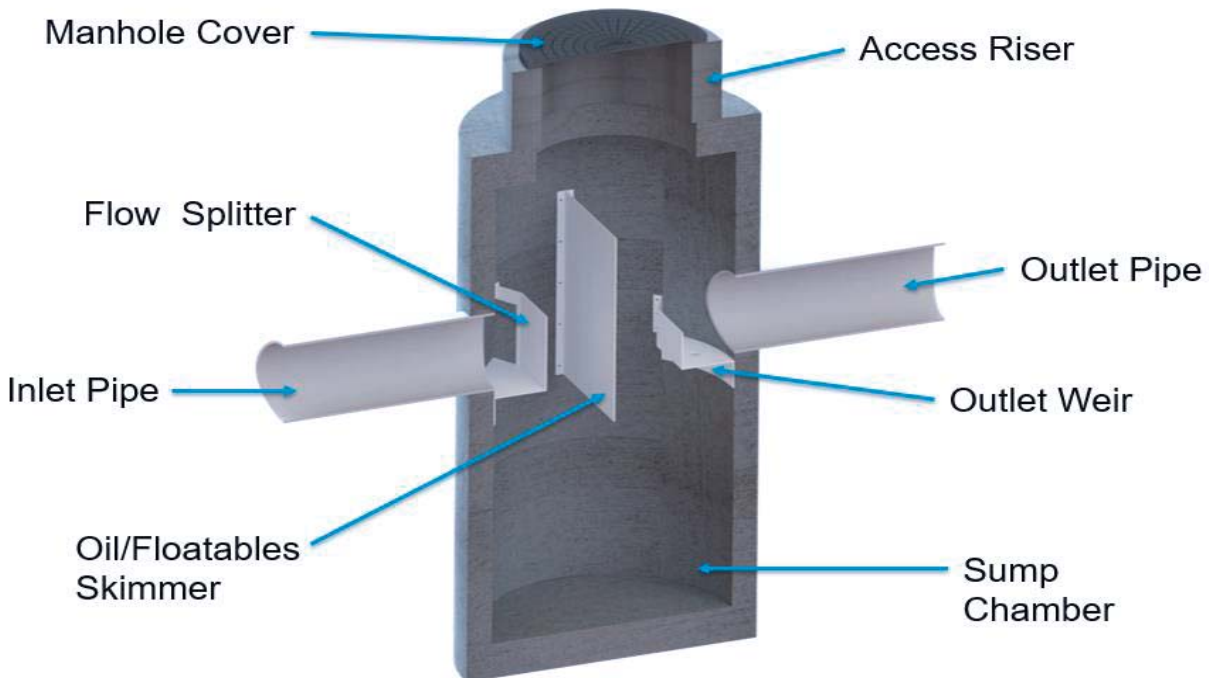

Figure 1 Cut-Away View

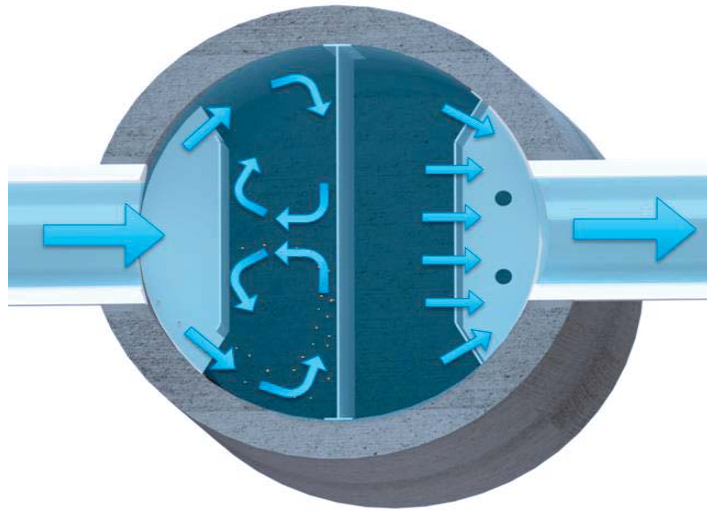

Figure 2 Operational Diagram

The oil/floatables skimmer is installed in the middle of the chamber and extends downward and upward to isolate free-floating oils and floatable trash and debris. Flows are forced to travel under the skimmer in the center of the system where the system is the widest thus creating a laminar flow under the weir and minimizing velocity. As water passes under the oil/floatables skimmer it rises back up and toward the outlet weir. The outlet weir extends across width of the outlet pipe and protrudes up slightly above the outlet pipe invert. The outlet weir is much wider than the pipe and creates a laminar flow from the system into the outlet pipe to reduce entrance velocity back into the pipe, while preventing channeling of flow as shown in **Figure 3**.

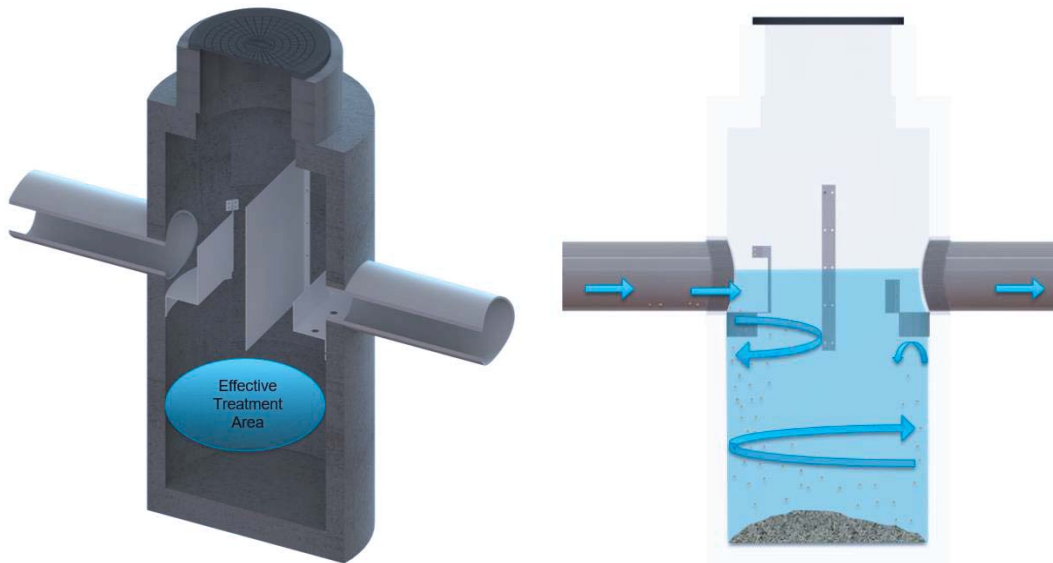

Figure 3 Effective Treatment Area and Flow Path Diagram

The unique design of the SciClone™, with a flow splitter, oil/floatables skimmer, and outlet weir maximizes the flow path and minimizes velocity for maximum performance. The system is designed to be installed online and process high flows internally. Higher flows are able to pass over the top of the flow splitter without impedance, under the oil/floatables skimmer and to the outlet. The outlet weir creates less turbulent conditions into the pipe and thus reduces head loss during peak flow conditions as shown in **Figure 4**. The outlet weir also contains one or more weep holes on the horizontal deck to allow the water level to return to a level even with the inlet of the outlet pipe following a storm event.

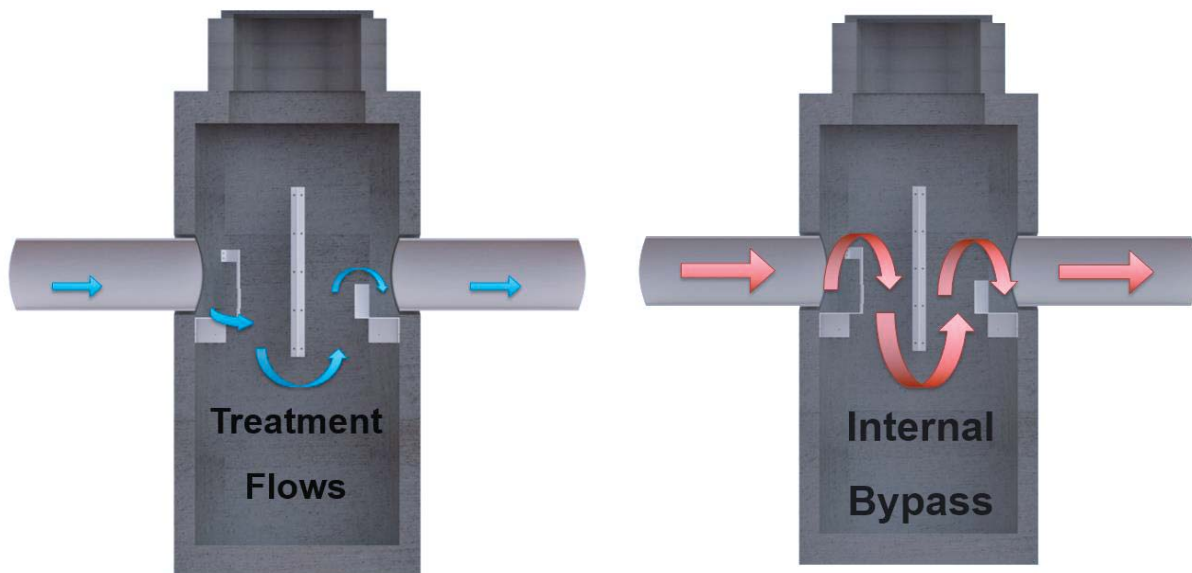

Figure 4 View During Treatment and Bypass Flows

2. Laboratory Testing

Good Harbour Laboratories (GHL), an independent water technology testing laboratory based in Mississauga, Ontario, Canada, was contracted by Bio Clean Environmental Services to test the SciClone™ in accordance with the *New Jersey Department of Environmental Protection Laboratory Protocol to Assess Total Suspended Solids Removal by a Hydrodynamic Sedimentation Manufactured Treatment Device (January 25, 2013)*. The device tested was a four-foot diameter SciClone™ (Model SC-4) consisting of internal components housed in a metal manhole. In commercial systems, the internal components are typically housed in a concrete manhole. The metal manhole of the test unit was equivalent to commercial concrete manholes in all key dimensions. The use of a metal manhole was proposed due to the difficulties associated with transporting and physically supporting the weight of a concrete vessel. Using a metal manhole in lieu of concrete is allowable by the protocol, since no measurable impact would be likely.

2.1 Test Setup

The design specifications of the SciClone™ hydrodynamic separator (HDS) are provided in **Table 1**. The test unit had a total sedimentation area of 12.6 ft² and a maximum treatment flow rate (MTFR) of 0.70 cfs (315 gpm).

Table 1 SciClone™ Model SC-4 Dimensions

MTFR		Diameter (ft)	Sediment Storage (ft ³)	Effective Treatment Area (ft ²)	Loading Rate (gpm/ft ²)
(cfs)	(gpm)				
0.70	315	4	18.8	12.6	25

The laboratory test set-up was a water flow loop, capable of moving water at a rate of up to 2.2 cfs. The test loop, illustrated in **Figure 5**, was comprised of water reservoirs, pumps, sediment filter, receiving tank and flow meters.

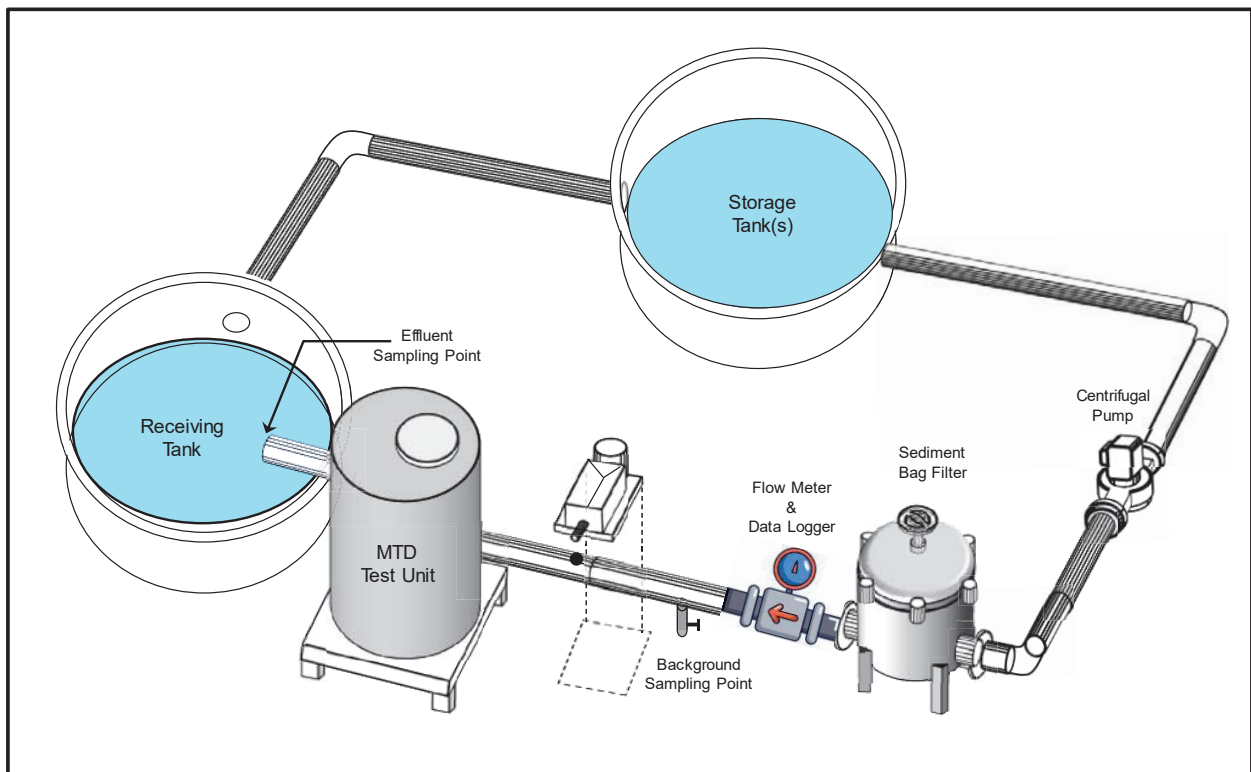

Figure 5 Test Flow Apparatus

Water Flow and Measurement

From the water supply tanks, water was pumped using either a WEG Model FC00312 (1 – 200 gpm) or an Armstrong Model 8X8X10 4380 (200 – 1000 gpm) centrifugal pump. Flow measurement was done using either a 3" Toshiba Model GF630 electromagnetic type flow meter with an accuracy of $\pm 0.5\%$ of reading (1 – 200 gpm) or a MJK Magflux Type 7200 flow meter Model 297237 with an accuracy of $\pm 0.25\%$ of reading (100 – 1000 gpm). The data logger used was a MadgeTech Process 101A data logger, configured to record a flow measurement once every minute.

The water in the flow loop was circulated through a filter housing containing high-efficiency pleated bag filters with a 0.5 μm absolute rating. The influent pipe was 24 inches in diameter and 132 inches long. Sediment addition was done through a port at the crown of the influent pipe, 118 inches upstream of the SciClone™. The sediment feeder was an Auger Feeders Model VF-1 volumetric screw feeder with vibratory hopper. The feeder had a 10-gallon hopper above the auger screw to provide a constant supply of sediment.

Water flow exited the SciClone™ and terminated with a free-fall into the receiving tank to complete the flow loop.

Sample Collection

Background water samples were collected in a 1L jar from a sampling port located upstream of the auger feeder. The sampling port was controlled manually by a ball valve (**Figure 6**) that was opened approximately 5 seconds prior to sampling.

Effluent samples were also grabbed by hand. The effluent pipe drained freely into the receiving tank and the effluent sample was taken at that point (**Figure 7**). The sampling technique was to take the grab sample by sweeping a wide-mouth 1 L jar through the stream of effluent flow such that the jar was full after a single pass.



Figure 6 Background Sampling Point



Figure 7 Effluent Sampling Point

Other Instrumentation and Measurement

Water temperature was taken using a MadgeTech MicroTemp data logger that was suspended inside the SciClone™ next to the effluent pipe. The MicroTemp was configured to take a temperature reading once every minute.

Run and sampling times were measured using a NIST traceable stopwatch, Control Company Model 62379-460.

The sediment feed samples that were taken during the run were collected in 500 mL jars and weighed on an analytical balance (Mettler Toledo, AB204-S).

2.2 Test Sediment

The test sediment was fed through an opening in the crown of the influent pipe, 118” upstream of the SciClone™. A funnel was used to direct the sediment into the pipe (**Figure 8**). The test sediment used for the removal efficiency study was custom blended by GHL using various commercially available silica sands; this particular batch was GHL lot # A016-042. Three samples of sediment were sent out for particle size analysis using the methodology of ASTM method D422-63. The samples were composite samples created by taking samples throughout the blending process and in various positions within the blending drum. The testing lab was Maxxam Analytics, an independent test lab also located in Ontario Canada. The PSD results are summarized in **Table 2** and shown graphically in **Figure 9**.



Figure 8 Sediment Addition Point

Table 2 PSD of Removal Efficiency Test Sediment (Lot # A016-042)

Particle Size (Microns)	Test Sediment Particle Size (% Less Than) \diamond				NJDEP Minimum Specification	QA/QC
	Sample 1	Sample 2	Sample 3	Average		
1000	100	100	100	100	98	PASS
500	98	97	98	98	93	PASS
250	91	90	91	91	88	PASS
150	80	79	81	80	73	PASS
100	60	59	60	60	58	PASS
75	51	49	52	51	48	PASS
50	44	44	45	44	43	PASS
20	36	36	37	36	33	PASS
8	19	19	20	19	18	PASS
5	12	13	13	13	8	PASS
2	6	8	8	7	3	PASS
d ₅₀	71 μm	79 μm	70 μm	73 μm	$\leq 75 \mu\text{m}$	PASS

\diamond Where required, particle size data has been interpolated to allow for comparison to the required particle size specification.

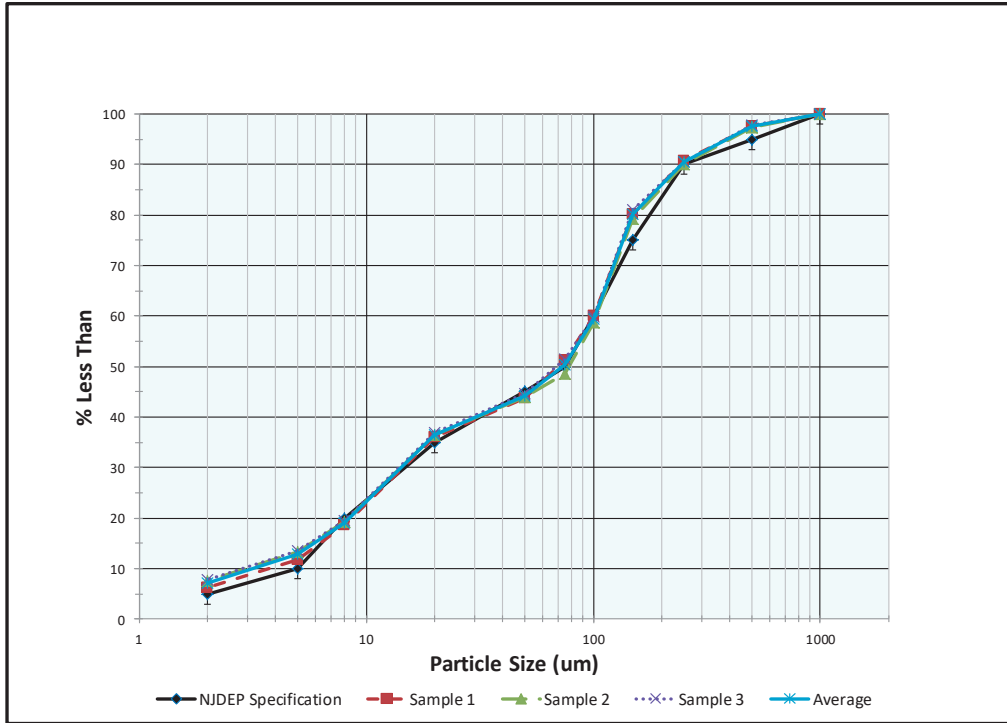

Figure 9 Average Particle Size Distribution of Removal Efficiency Test Sediment

For the scour test, the test sediment was also blended by GHIL using commercially available silica sands, GHIL lot# A017-001. The scour test sediment PSD results are summarized in **Table 3** and shown graphically in **Figure 10**.

Table 3 PSD of Scour Test Sediment (Lot # A017-001)

Particle Size (µm)	Test Sediment Particle size (% Less Than) ◇				NJDEP Minimum Specification
	Sample 1	Sample 2	Sample 3	Average	
1000	100	99	100	100	98
500	95	92	94	94	88
250	63	58	61	61	53
150	52	43	46	47	38
100	33	20	23	25	23
75	22	10	13	15	8
50	14	4	6	8	0

◇ Where required, particle size data has been interpolated to allow for comparison to the required particle size specification.

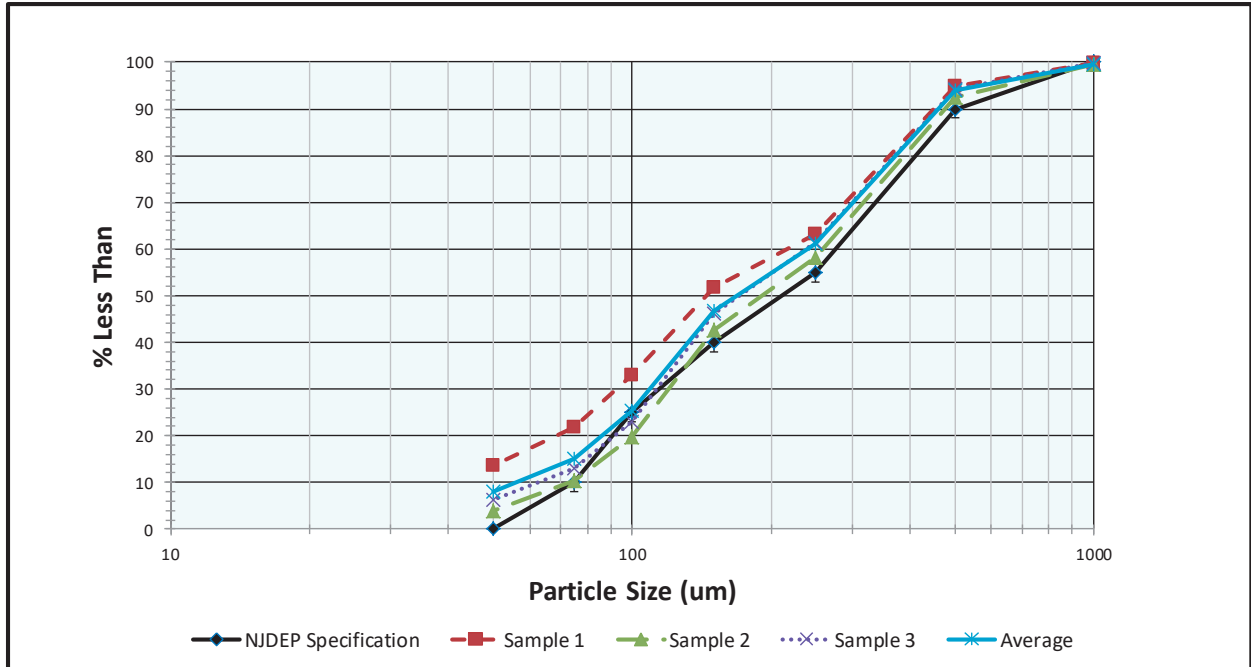

Figure 10 Particle Size Distribution of Scour Test Sediment

2.3 Removal Efficiency Testing

Removal testing was conducted on a clean unit with a false floor installed at 50% sump sediment storage depth, 9 inches above the device floor. Removal efficiency testing was performed as specified in Section 5 of the NJDEP Laboratory Protocol for Hydrodynamic Sedimentation MTDs.

The test sediment was sampled six times per run to confirm the sediment feed rate. Each sediment feed rate sample was collected in a 500-mL jar over an interval timed to the nearest second and was a minimum 0.1 liter or the collection interval did not exceed one minute, whichever came first.

Effluent grab sampling began following three MTD detention times after the initial sediment feed sample. The time interval between sequential samples was 1 minute, however, when the test sediment feed was interrupted for measurement, the next effluent sample was collected following three MTD detention times from the time the sediment feed was re-established. A total of 15 effluent samples were taken during each run.

Background water samples were taken with the odd-numbered effluent samples. GHl performed analysis on all the background and effluent samples.

2.4 Scour Testing

Prior to the start of testing, the false floor was re-installed 4 inches lower than before and sediment was loaded into the sump of the SciClone™ and leveled at a depth of 4 inches. The final height of the sediment was at an elevation equivalent to 50% of the maximum sediment storage capacity of the MTD. After loading of the sediment, the unit was gradually filled with clear water, so as not

to disturb the sediment, to the invert of the inlet pipe. The filled unit was allowed to sit for 89 hours.

The scour test was conducted at a flow rate of 630 gpm (1.4 cfs), two times the MTFR.

During the scour test, the water flow rate and temperature were recorded once every minute using a MadgeTech Process 101 data logger and a MicroTemp data logger. Testing commenced by gradually increasing the water flow into the system until the target flow rate was achieved (within five minutes of commencing the test). Background and effluent sampling began five minutes after adding water to the system. Sampling of background and effluent was completed as per the removal efficiency test. An effluent grab sample was taken once every two minutes, starting after achieving the target flow rate, until a total of 15 effluent samples were taken. A total of eight background water samples were collected at evenly spaced intervals throughout the scour test.

3. Performance Claims

Total Suspended Solids (TSS) Removal Rate

The TSS removal rate of the SciClone™ was calculated using the weighted method required by the NJDEP HDS MTD protocol. Based on a MTFR of 0.70 cfs, the SciClone™ achieved a weighted TSS removal rate of at least 50%.

Maximum Treatment Flow Rate (MTFR).

The SciClone™ unit had a total sedimentation area of 12.6 ft² and demonstrated a maximum treatment flow rate (MTFR) of 0.70 cfs (315 gpm). This corresponds to a surface loading rate of 25 gpm/ft² of sedimentation area.

Maximum Sediment Storage Depth and Volume

The maximum sediment storage depth is 18" which equates to 18.8 ft³ of sediment storage volume. A sediment storage depth of 9 inches corresponds to 50% full sediment storage capacity (9.4 ft³).

Effective Treatment/Sedimentation Area

The effective treatment area is 12.6 ft².

Detention Time and Wet Volume

The wet volume for the SciClone™ is 470 gallons. The detention time of the SciClone™ is dependent upon flow rate. The minimum design detention time, calculated by dividing the treatment volume by the MTFR of 315 gpm, is 89.5 seconds.

Online/Offline Installation

Based on the scour testing results shown in Section 4.2 the SciClone™ qualifies for online installation.

4. Supporting Documentation

To support the performance claims, copies of the laboratory test reports, including all collected and measured data; all data from performance evaluation test runs; spreadsheets containing original data from all performance test runs; all pertinent calculations; etc. were made available to NJCAT for review. It was agreed that as long as such documentation could be made available upon request that it would not be prudent or necessary to include all this information in this verification report. All supporting documentation will be retained securely by GHM and has been provided to NJCAT.

4.1 Removal Efficiency Testing

A total of 5 removal efficiency testing runs were completed in accordance with the NJDEP HDS protocol. The target flow rate ranged from 25 – 125% MTRF and the target influent sediment concentration was 200 mg/L. The results from all 5 runs were used to calculate an annualized weighted removal efficiency for the SciClone™.

The total water volume and average flow rate per run were calculated from the data collected by the flow data logger, one reading every minute. The average influent sediment concentration for each test flow was determined by mass balance. The amount of sediment fed into the auger feeder during dosing, and the amount remaining at the end of a run, was used to determine the amount of sediment fed during a run. The sediment mass was corrected for the mass of the six feed rate samples taken during the run. The mass of the sediment fed was divided by the volume of water that flowed through the SciClone™ during dosing to determine the average influent sediment concentration for each run.

Six feed rate samples were collected at evenly spaced intervals during the run to ensure the rate was stable. The COV of the samples had to be < 0.10 per the NJDEP protocol. The feed rate samples were also used to calculate an influent concentration in order to double check the concentration calculated by mass balance.

The average effluent sediment concentration was adjusted for the background sediment concentration. In cases where the reported background sediment concentration was less than 2.3 mg/L (the method quantitation limit), 2 mg/L was used in calculating the adjusted effluent concentration.

Removal efficiency for each test run was computed as follows:

$$\text{Removal Efficiency (\%)} = \left(\frac{\text{Average Influent Concentration} - \text{Adjusted Average Effluent Concentration}}{\text{Average Influent Concentration}} \right) \times 100\%$$

The data collected for each removal efficiency run is presented below:

25% MTFR

Table 4 Sampling Schedule - 25% MTFR

Runtime (min)	Sampling Schedule		
	Sediment Feed	Background	Effluent
0	1		
18.91		1	1
19.91			2
20.91	2	2	3
39.81			4
40.81		3	5
41.81	3		6
60.72		4	7
61.72			8
62.72	4	5	9
81.62			10
82.62		6	11
83.62	5		12
102.53		7	13
103.53			14
104.53	6	8	15
105.53	End of Testing		
MTD Detention Time = 5.968 minutes Target Sediment Sampling Time = 60 seconds			

Table 5 Water Flow and Temperature - 25% MTFR

Run Parameters	Water Flow Rate (GPM)				Maximum Water Temperature (°F)
	Target	Actual	Difference	COV	
		78.8	77.4	-1.8%	0.004
QA/QC Limit	-	-	±10% PASS	0.03 PASS	80 PASS

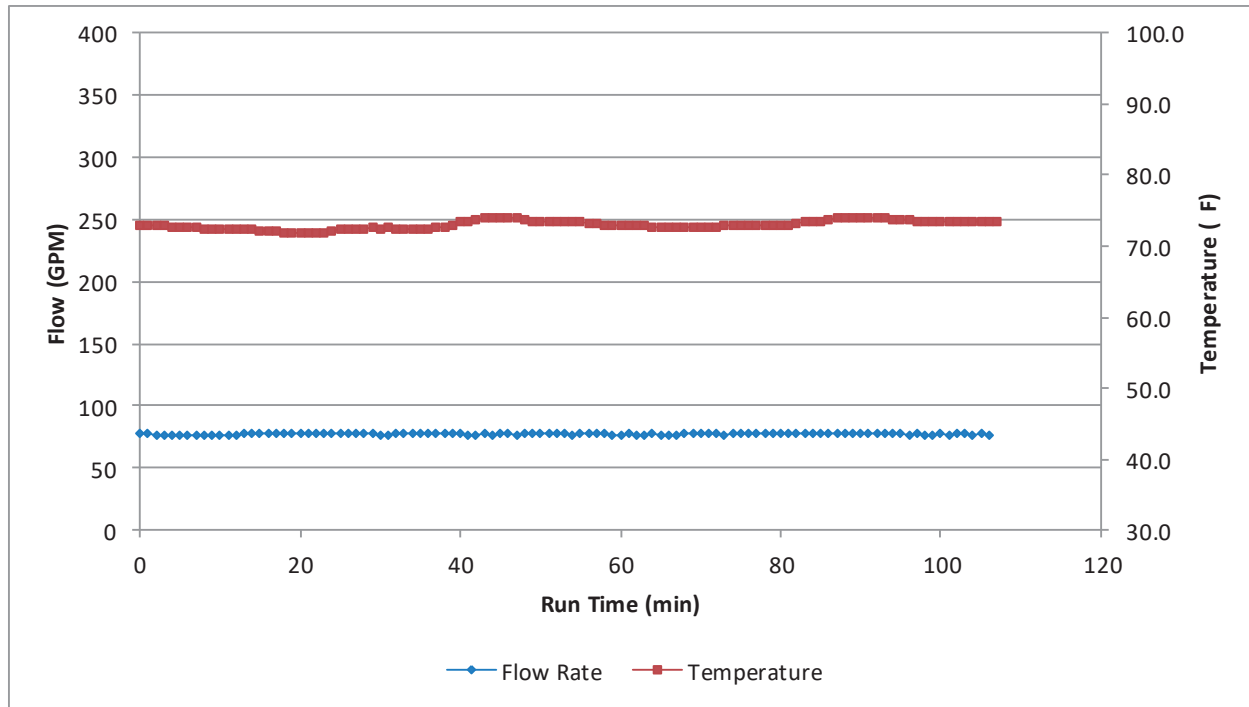

Figure 11 Water Flow and Temperature - 25% MTR

Table 6 Sediment Feed Rate Summary – 25% MTR

Sediment Feed Rate (g/min)		Sediment Mass Balance	
1	59.595	Starting Weight of Sediment (lbs.)	58.599
2	58.410		
3	60.436	Recovered Weight of Sediment (lbs.)	44.765
4	59.974		
5	56.952	Mass of Sediment Used (lbs.)	13.834
6	56.557	Volume of Water Through MTD During Dosing (gal)	7,700
Average	58.654		
COV	0.028	Average Influent Sediment Concentration (mg/L)	203.2*
QA/QC Limit	0.10 PASS	QA/QC Limit	180 – 220 mg/L PASS

*Corrected for sediment feed rate samples

Table 7 SSC and Removal Efficiency - 25% MTFR

		Suspended Sediment Concentration (mg/L)														
Sample #	1	2	3	4	5	6	7	8	9	10	11	12	13	14	15	
Effluent	80.4	80.9	80.8	83.8	83.8	84.4	85.5	84.8	85.3	84.5	84.4	83.5	86.7	86.8	86.1	
Background	2		2		2		2		2		2		2		2	
Adjusted Effluent	78.4	78.9	78.8	81.8	81.8	82.4	83.5	82.8	83.3	82.5	82.4	81.5	84.7	84.8	84.1	
Average Adjusted Effluent Concentration					82.1 mg/L			Removal Efficiency					59.6%			

50% MTFR

Table 8 Sampling Schedule - 50% MTFR

Runtime (min)	Sampling Schedule		
	Sediment Feed	Background	Effluent
0	1		
9.95		1	1
10.95			2
11.95	2	2	3
21.91			4
22.91		3	5
23.91	3		6
33.86		4	7
34.86			8
35.86	4	5	9
45.81			10
46.81		6	11
47.81	5		12
57.76		7	13
58.76			14
59.76	6	8	15
60.76	End of Testing		
MTD Detention Time = 2.984 minutes Target Sediment Sampling Time = 60 seconds			

Table 9 Water Flow and Temperature - 50% MTR

Run Parameters	Water Flow Rate (GPM)				Maximum Water Temperature (°F)
	Target	Actual	Difference	COV	
		157.5	157.9	0.3%	0.011
QA/QC Limit	-	-	±10% PASS	0.03 PASS	80 PASS

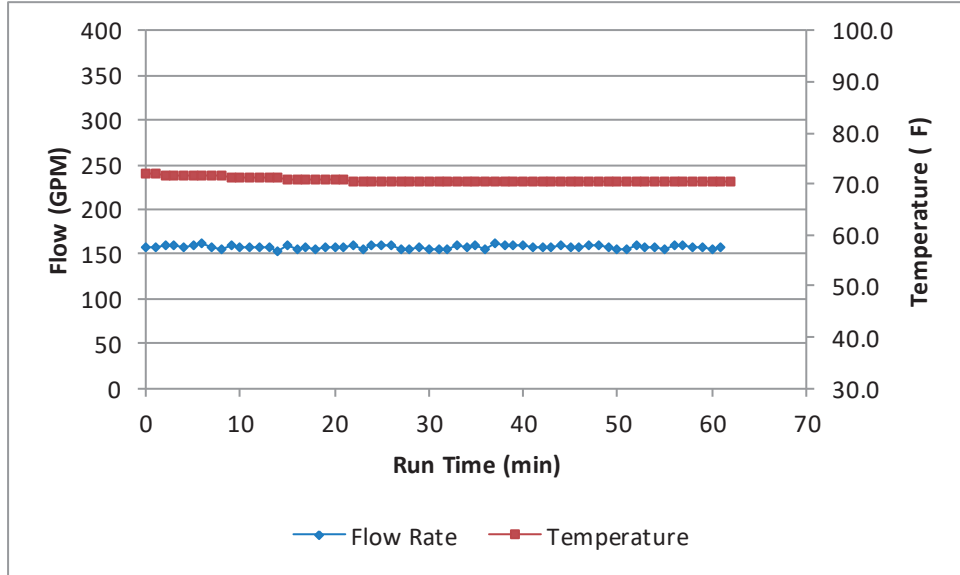

Figure 12 Water Flow and Temperature - 50% MTR

Table 10 Sediment Feed Rate Summary – 50% MTR

Sediment Feed Rate (g/min)		Sediment Mass Balance	
1	123.259	Starting Weight of Sediment (lbs.)	62.468
2	121.110		
3	119.319	Recovered Weight of Sediment (lbs.)	46.341
4	117.934		
5	120.858	Mass of Sediment Used (lbs.)	16.127
6	119.107	Volume of Water Through MTD During Dosing (gal)	8,650
Average	120.265		
COV	0.016	Average Influent Sediment Concentration (mg/L)	201.4*
QA/QC Limit	0.10 PASS	QA/QC Limit	180 – 220 mg/L PASS

*Corrected for sediment feed rate samples

Table 11 SSC and Removal Efficiency - 50% MTFR

		Suspended Sediment Concentration (mg/L)														
Sample #	1	2	3	4	5	6	7	8	9	10	11	12	13	14	15	
Effluent	93.0	92.8	93.3	94.4	95.5	96.2	95.8	95.6	97.8	99.5	99.7	98.8	98.3	98.8	99.5	
Background	2		2		2		2		2		2		2		2	
Adjusted Effluent	91.0	90.8	91.3	92.4	93.5	94.2	93.8	93.6	95.8	97.5	97.7	96.8	96.3	96.8	97.5	
Average Adjusted Effluent Concentration					94.6 mg/L			Removal Efficiency					53.0%			

75% MTFR

Table 12 Sampling Schedule - 75% MTFR

Runtime (min)	Sampling Schedule		
	Sediment Feed	Background	Effluent
0	1		
6.89		1	1
7.89			2
8.89	2	2	3
15.77			4
16.77		3	5
17.77	3		6
24.66		4	7
25.66			8
26.66	4	5	9
33.54			10
34.54		6	11
35.54	5		12
42.43		7	13
43.43			14
44.43	6	8	15
45.34	End of Testing		
MTD Detention Time = 1.989 minutes Target Sediment Sampling Time = 55 seconds			

Table 13 Water Flow and Temperature - 75% MTR

Run Parameters	Water Flow Rate (GPM)				Maximum Water Temperature (°F)
	Target	Actual	Difference	COV	
		236.3	233.2	-1.3%	0.011
QA/QC Limit	-	-	±10% PASS	0.03 PASS	80 PASS

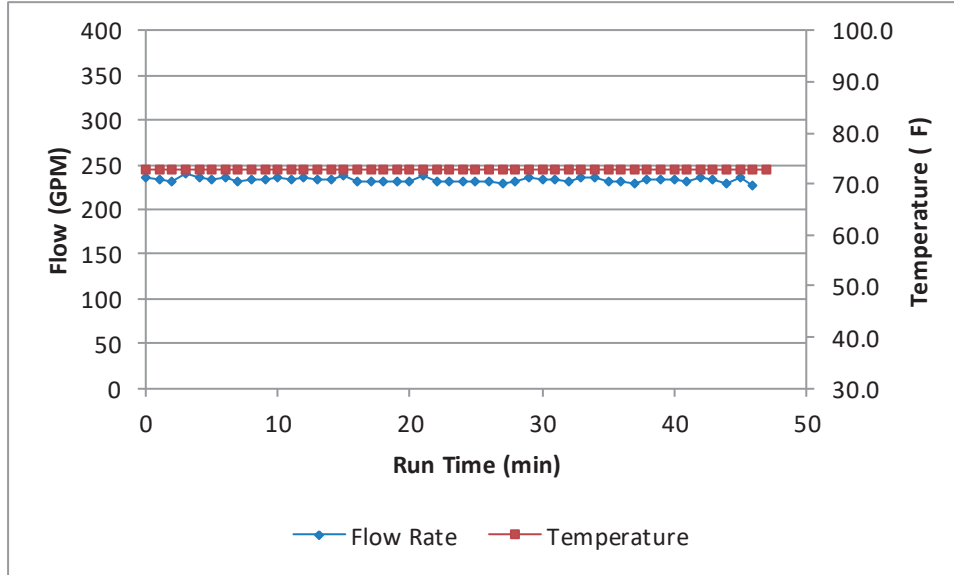

Figure 13 Water Flow and Temperature - 75% MTR

Table 14 Sediment Feed Rate Summary – 75% MTR

Sediment Feed Rate (g/min)		Sediment Mass Balance	
1	187.862	Starting Weight of Sediment (lbs.)	64.562
2	181.646		
3	180.978	Recovered Weight of Sediment (lbs.)	46.330
4	179.699		
5	180.717	Mass of Sediment Used (lbs.)	18.232
6	182.950	Volume of Water Through MTD During Dosing (gal)	9,296
Average	182.309		
COV	0.016	Average Influent Sediment Concentration (mg/L)	206.6* mg/L
QA/QC Limit	0.10 PASS	QA/QC Limit	180 – 220 mg/L PASS

*Corrected for sediment feed rate samples

Table 15 SSC and Removal Efficiency - 75% MTFR

		Suspended Sediment Concentration (mg/L)														
Sample #	1	2	3	4	5	6	7	8	9	10	11	12	13	14	15	
Effluent	107.0	113.0	109.0	109.0	109.0	104.0	110.0	111.9	113.0	110.0	111.0	114.4	115.7	110.0	114.0	
Background	2		2		2		2		2		2		2		2	
Adjusted Effluent	105.0	111.0	107.0	107.0	107.0	102.0	108.0	109.9	111.0	108.0	109.0	112.4	113.7	108.0	112.0	
Average Adjusted Effluent Concentration					108.7 mg/L					Removal Efficiency					47.4%	

100% MTFR

Table 16 Sampling Schedule - 100% MTFR

Runtime (min)	Sampling Schedule		
	Sediment Feed	Background	Effluent
0	1		
5.14		1	1
6.14			2
7.14	2	2	3
12.29			4
13.29		3	5
14.29	3		6
19.43		4	7
20.43			8
21.43	4	5	9
26.57			10
27.57		6	11
28.57	5		12
33.72		7	13
34.72			14
35.72	6	8	15
36.38	End of Testing		
MTD Detention Time = 1.492 minutes Target Sediment Sampling Time = 40 seconds			

Table 17 Water Flow and Temperature - 100% MTR

Run Parameters	Water Flow Rate (GPM)				Maximum Water Temperature (°F)
	Target	Actual	Difference	COV	
		315.0	310.8	-1.3%	0.009
QA/QC Limit	-	-	±10% PASS	0.03 PASS	80 PASS

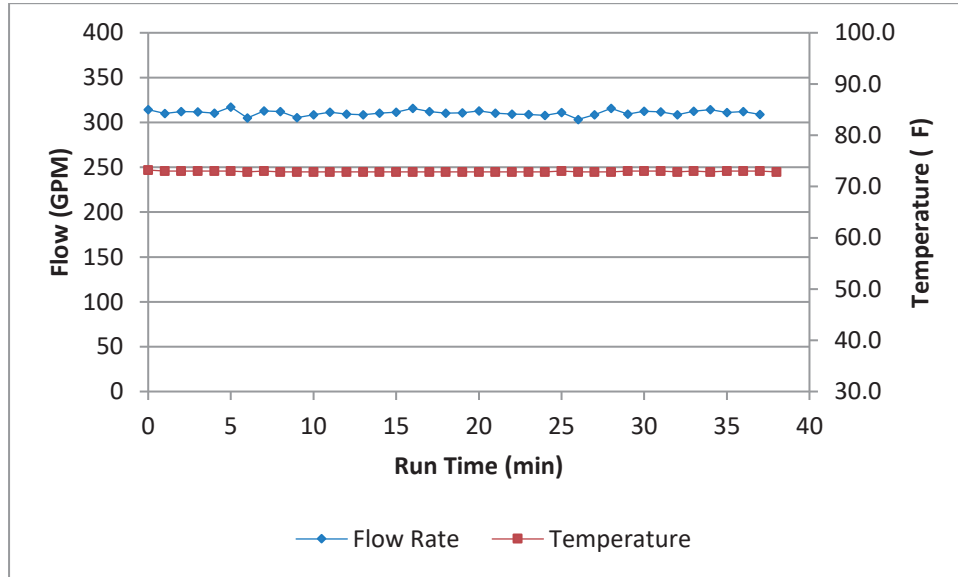

Figure 14 Water Flow and Temperature - 100% MTR

Table 18 Sediment Feed Rate Summary – 100% MTR

Sediment Feed Rate (g/min)		Sediment Mass Balance	
1	238.782	Starting Weight of Sediment (lbs.)	67.494
2	243.234		
3	239.372	Recovered Weight of Sediment (lbs.)	48.105
4	239.993		
5	246.005	Mass of Sediment Used (lbs.)	19.389
6	247.750	Volume of Water Through MTD During Dosing (gal)	10,059
Average	242.523		
COV	0.015	Average Influent Sediment Concentration (mg/L)	205.5*
QA/QC Limit	0.10 PASS	QA/QC Limit	180 – 220 mg/L PASS

*Corrected for sediment feed rate samples

Table 19 SSC and Removal Efficiency - 100% MTR

Suspended Sediment Concentration (mg/L)															
Sample #	1	2	3	4	5	6	7	8	9	10	11	12	13	14	15
Effluent	116.0	126.2	124.0	125.6	123.3	124.1	123.3	123.3	128.0	126.0	126.3	128.9	126.3	125.1	125.8
Background	2		2		2		2		2		2		2		2
Adjusted Effluent	114.0	124.2	122.0	123.6	121.3	122.1	121.3	121.3	126.0	124.0	124.3	126.9	124.3	123.1	123.8
Average Adjusted Effluent Concentration				122.8 mg/L			Removal Efficiency					40.2 %			

125% MTR

Table 20 Sampling Schedule - 125% MTR

Runtime (min)	Sampling Schedule		
	Sediment Feed	Background	Effluent
0	1		
4.08		1	1
5.08			2
6.08	2	2	3
10.16			4
11.16		3	5
12.16	3		6
16.24		4	7
17.24			8
18.24	4	5	9
22.32			10
23.32		6	11
24.32	5		12
28.41		7	13
29.41			14
30.41	6	8	15
30.91	End of Testing		
MTD Detention Time = 1.194 minutes Target Sediment Sampling Time = 30 seconds			

Table 21 Water Flow and Temperature - 125% MTR

Run Parameters	Water Flow Rate (GPM)				Maximum Water Temperature (°F)
	Target	Actual	Difference	COV	
		393.8	392.5	-0.3%	0.010
QA/QC Limit	-	-	±10% PASS	0.03 PASS	80 PASS

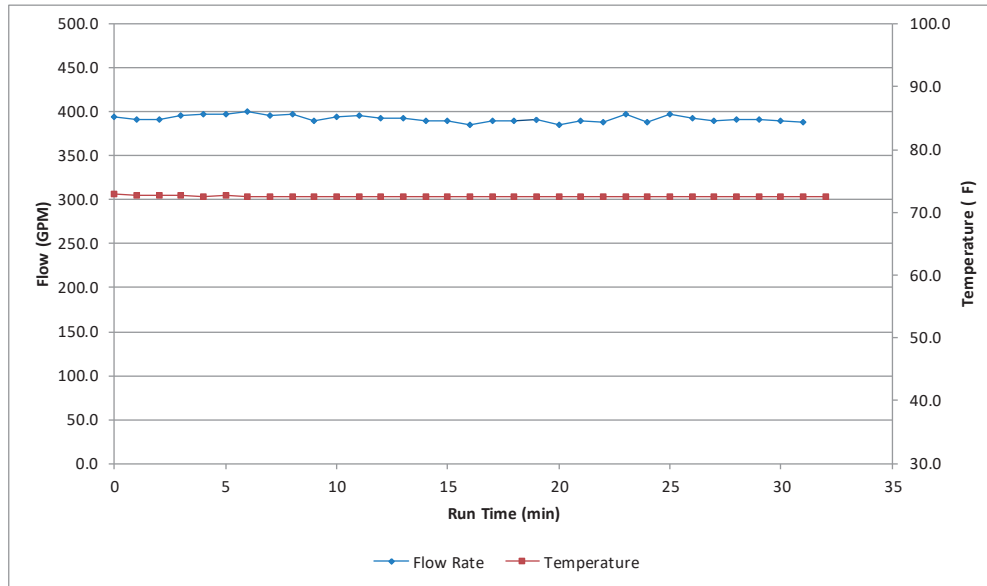

Figure 15 Water Flow and Temperature - 125% MTR

Table 22 Sediment Feed Rate Summary – 125% MTR

Sediment Feed Rate (g/min)		Sediment Mass Balance	
1	295.073	Starting Weight of Sediment (lbs.)	79.697
2	296.534		
3	298.519	Recovered Weight of Sediment (lbs.)	59.282
4	297.235		
5	302.401	Mass of Sediment Used (lbs.)	20.415
6	301.186	Volume of Water Through MTD During Dosing (gal)	10,954
Average	298.491		
COV	0.009	Average Influent Sediment Concentration (mg/L)	201.8*
QA/QC Limit	0.10 PASS	QA/QC Limit	180 – 220 mg/L PASS

*Corrected for sediment feed rate samples

Table 23 SSC and Removal Efficiency - 125% MTR

Sample #	Suspended Sediment Concentration (mg/L)															
	1	2	3	4	5	6	7	8	9	10	11	12	13	14	15	
Effluent	123.0	127.5	129.3	124.9	128.7	122.0	129.4	132.9	134.5	123.1	106.0	153.6	126.6	136.4	132.9	
Background	2		2		2		2.5		2		2		2		2	
Adjusted Effluent	121.0	125.5	127.3	122.9	126.7	119.8	126.9	130.7	132.5	121.1	104.0	151.6	124.6	134.4	130.9	
Average Adjusted Effluent Concentration				126.7 mg/L			Removal Efficiency						37.2%			

Annualized Weighted Removal Efficiency

The annualized weighted removal efficiency for sediment in stormwater has been calculated using the rainfall weighting factors provided in the NJDEP laboratory test protocol. The SciClone™ annual weighted removal for a MTR of 0.70 cfs (315 gpm) is 50.03%, as shown in **Table 24**.

Table 24 Annualized Weighted Removal Efficiency for SciClone™

%MTR	Removal Efficiency (%)	Annual Weighting Factor	Weighted Removal Efficiency (%)
25	59.6	0.25	14.90
50	53.0	0.30	15.90
75	47.4	0.20	9.48
100	40.2	0.15	6.03
125	37.2	0.10	3.72
Annualized Weighted Removal Efficiency			50.03

4.2 Scour Testing

Scour testing was conducted in accordance with Section 4 of the NJDEP Laboratory Protocol to Assess Total Suspended Solids Removal by a Hydrodynamic Sedimentation MTD. Testing was conducted at a target flow rate of 630 gpm, 200% of the maximum treatment flow rate (MTR).

In preparation for the scour test, the sump of the SciClone™ was cleaned out to remove all the accumulated sediment from the previous removal efficiency testing. A false floor was installed 4 inches below the depth of the 50% maximum sediment storage height. The sump was then loaded with scour test sediment so that when levelled, the sediment formed a layer at least 4 inches thick,

confirmed by measuring the sediment thickness with a yard stick. After sediment loading, the sump was filled with water and allowed to sit for 89 hours.

Scour testing began by gradually increasing the flow rate to the target flow within a 5-minute period. Effluent and background samples were taken from the same locations as for the removal efficiency test, starting 5 minutes after flow was initiated. The sampling frequency is summarized in **Table 25**.

Table 25 Scour Test Sampling Frequency

Sample/ Measurement Taken	Run Time (min.)															
	0	2	4	6	8	10	12	14	16	18	20	22	24	26	28	30
Effluent		X	X	X	X	X	X	X	X	X	X	X	X	X	X	X
Background	X		X		X		X		X		X		X		X	

Note: The Run Time of 0 minutes was the time that the 1st background sample was taken, just after achieving the target flow.

Table 26 Water Flow and Temperature - Scour Test

Run Parameters	Water Flow Rate (GPM)				Maximum Water Temperature (°F)
	Target	Actual	Difference	COV	
	630	630.2	0.03 %	0.005	
QA/QC Limit	-	-	±10% PASS	0.03 PASS	80 PASS

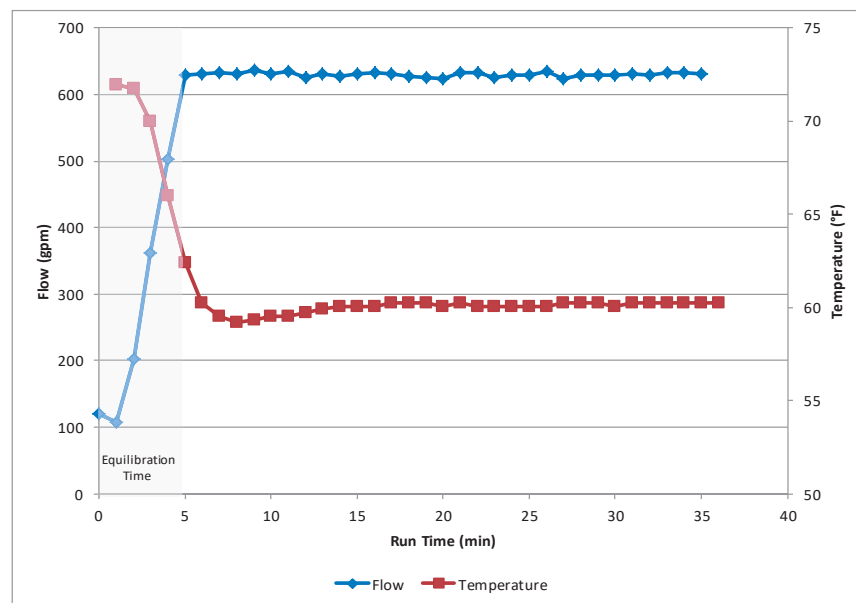

Figure 16 Water Flow and Temperature - Scour Test

A sharp decrease in water temperature was observed at the start of the scour test, as illustrated in **Figure 16**. The reason for this is that the system sat idle for 89 hours after the sump was preloaded for the test. During this time, the water in the SciClone and the piping warmed up to close to room temperature. As testing began, the warm water was replaced by the colder water that was in the system storage tanks. The temperature eventually reached equilibrium at approximately 60 °F. At no time during the test did the water temperature exceed 80 °F.

The effluent and background SSC results are reported in **Table 27**. The adjusted effluent concentration was calculated as:

$$\text{Adjusted Effluent Concentration} \left(\frac{\text{mg}}{\text{L}} \right) = \text{Initial Concentration} - \text{Background Concentration}$$

The SSC method reporting limit was 2.3 mg/L. Any results below this value were reported as 2 mg/L for calculation purposes. For effluent samples that did not have a corresponding background sample, the background value was interpolated from the previous and subsequent samples. The average adjusted effluent concentration was 0.2 mg/L. Therefore, when operated at 200% of the MTFR, the SciClone™ meets the criteria for online use.

Table 27 Suspended Sediment Concentrations for Scour Test

		Scour Suspended Sediment Concentration (mg/L)														
Sample #		1	2	3	4	5	6	7	8	9	10	11	12	13	14	15
Effluent		2.0	2.0	2.0	2.0	2.0	2.3	2.0	2.0	2.4	2.6	2.3	2.0	2.6	2.9	2.5
Background	2		2		2		2		2		2		2.6		2	
Adjusted Effluent		0	0	0	0	0	0.3	0	0	0.4	0.6	0	0	0.3	0.9	0.5
Average Adjusted Effluent Concentration							0.2 mg/L									

5. Design limitations

Bio Clean Environmental Services, Inc. provides engineering support to clients on all projects. Each system prior to submittal is evaluated and properly designed/sized to meet site specific conditions including treatment and bypass flow rates, load rating requirements, and pipe depth. All site and design constraints will be addressed during the design and manufacturing process.

Required Soil Characteristics

The SciClone™ is delivered to the job site as a complete pre-assembled unit housed in a concrete structure designed to meet site specific soil conditions, corrosiveness, top and lateral loading, and ground water. The system can be used in all soil types. A copy of the geotechnical report along with surface loading requirements are reviewed and verified for each project.

Slope

The SciClone™ is most commonly used in a piped-in configuration in which one or more pipes enter the side of the system subsurface. In general, it is not recommended that the pipe slope into the system exceed 10% nor be less than 0.5%. Slopes higher than 10% will cause increased velocities which could affect the performance. Slopes less than 0.5% could cause sediment to accumulate in the bottom of the inflow pipe and affect its hydraulic capacity.

The SciClone™ is usually not affected by variations in slope of the finish surface as the unit is buried underground. Risers of various heights can be used to bring access to the system up to finish surface. In these configurations finish surface slope is more constrained and will require design review to ensure appropriate configuration.

Maximum Flow Rate

Maximum treatment flow rate is dependent on model size. The SciClone™ will be sized based upon the NJCAT tested hydraulic loading rate of 25 gallons per minute per square foot of settling surface area. Section 6 includes details pertaining to inspection and maintenance of the SciClone™.

Maintenance Requirements

Requirements pertaining to maintenance of the SciClone™ will vary depending on pollutant loading and individual site conditions. It is recommended that the system be inspected at least twice during the first year as a way to determine loading conditions for each site. These first year inspections can be used as a way to establish inspection and maintenance frequency for subsequent years.

Driving Head

Driving head will vary for a given SciClone™ model based on the site specific configuration. Design support is provided for all projects including site-specific drawings/cut sheets which show elevations of pipes and finish surface. Peak and treatment flow rates will also be evaluated to ensure the system is properly designed from a hydraulic standpoint.

Installation Limitations

With each installation Bio Clean Environmental, Inc. provides contractors with instructions prior to delivery. Contractors can request onsite assistance from an installation technician during delivery and installation. Pick weights and lifting details are also provided prior to delivery so the contractor can prepare appropriate equipment onsite to set the unit.

Configurations

The SciClone™ is available in various configurations. The units can be installed online or offline. The SciClone™ has an internal bypass which allows for it to be installed online without the need for any external high flow diversion structure.

Structural Load Limitations

The SciClone™ is housed in a pre-cast concrete structure. Most standard structures are designed to handle indirect traffic loads with minimal cover. For deeper installation, or installation requiring direct traffic rating or higher, the structure will be designed and modified with potentially thicker tops, bottoms and/or walls to handle the additional loading. Various access hatch options are available for

parkway, indirect traffic, direct traffic and other higher loading requirements such as airports or loading docks.

Pre-treatment Requirements

SciClone™ has no pre-treatment requirements.

Limitations in Tailwater

Site specific tailwater conditions must be assessed on each individual project. Tailwater conditions increase the amount of driving head required for optimal system operation. The manufacturer's internal protocols require that these conditions are discussed with the engineer of record and that a solution be implemented to adjust for any design variations caused by tailwater conditions at both treatment and bypass flow rates.

Depth to Seasonal High-Water Table

High groundwater conditions will not affect the operation of the SciClone™ as it is a closed system. In conditions where high groundwater is present, various measures are employed by the engineering department of Bio Clean Environmental Services to ensure that there are no negative consequences caused by the high groundwater. Various measures can be employed such as waterproofing the inside and outside of the structure with an approved coating. A footing can also be added to the bottom of the structure to increase its footprint and offset any buoyancy concerns.

6. Maintenance Plans

As with all stormwater BMPs, inspection and maintenance on the SciClone™ Hydrodynamic Separator is necessary. Stormwater regulations require that all BMPs be inspected and maintained to ensure they are operating as designed to allow for effective pollutant removal and provide protection to receiving water bodies. It is recommended that inspections be performed multiple times during the first year to assess site specific loading conditions. This is recommended because pollutant loading can vary greatly from site to site. Variables such as nearby soil erosion or construction sites, winter sanding of roads, amount of daily traffic and land use can increase pollutant loading on the system. The first year of inspections can be used to set inspection and maintenance intervals for subsequent years. Without appropriate maintenance a BMP can exceed its storage capacity, which can negatively affect its continued performance in removing and retaining captured pollutants. The SciClone™ Operation and Maintenance Manual is available at: <http://www.biocleanenvironmental.com/wp-content/uploads/2017/07/Operations-Maintenance-SciClone-1.pdf>

Inspection Equipment

Following is a list of equipment to allow for simple and effective inspection of the SciClone™ Hydrodynamic Separator:

- Inspection Form (contained in Operations & Maintenance (O&M) Manual).
- Flashlight.
- Manhole hook or appropriate tools to access hatches and covers.
- Appropriate traffic control signage and procedures.
- Measuring pole and/or tape measure.

- Protective clothing and eye protection.
- Note: Entering a confined space requires appropriate safety and certification. It is generally not required for routine inspections of the system.

Inspection Steps

The core to any successful stormwater BMP maintenance program is routine inspections. The inspection steps required on the SciClone™ Hydrodynamic Separator are quick and easy. As mentioned above the first year should be seen as the maintenance interval establishment phase. During the first year more frequent inspections should occur in order to gather loading data and maintenance requirements for that specific site. This information can be used to establish a base for long-term inspection and maintenance interval requirements.

The SciClone™ Hydrodynamic Separator can be inspected through visual observation without entry into the system. All necessary pre-inspection steps must be carried out before inspection occurs, especially traffic control and other safety measures to protect the inspector and near-by pedestrians from any dangers associated with an open access hatch or manhole. Once these access covers have been safely opened the inspection process can proceed:

- Prepare the inspection form by writing in the necessary information including project name, location, date and time, unit number and other info (see inspection form).
- Observe the inside of the system through the access hatches. If minimal light is available and vision into the unit is impaired utilize a flashlight to see inside the system.
- Look for any out of the ordinary obstructions in the inflow pipe, sump chamber, or outflow pipe. Write down any observations on the inspection form.
- Through observation and/or digital photographs estimate the amount of floatable debris accumulated on the influent side of the oil/floatables skimmer. Record this information on the inspection form. Next utilizing a tape measure or measuring stick estimate the amount of sediment accumulated in the sump. Record this depth on the inspection form.
- Finalize inspection report for analysis by the maintenance manager to determine if maintenance is required.

Maintenance Indicators

Based upon observations made during inspection, maintenance of the system may be required based on the following indicators:

- Missing or damaged internal components.
- Obstructions in the system or its inlet or outlet.
- Excessive accumulation of floatables in the sump chambers in which the length and width of the chambers behind oil/floatables skimmer is fully impacted extending down more than 9”.
- Excessive accumulation of sediment in the sump chamber of more than 18” in depth.

Maintenance Equipment

It is recommended that a vacuum truck be utilized to minimize the time required to maintain the SciClone™ Separator:

- Maintenance Form (contained in O&M Manual).
- Flashlight.
- Manhole hook or appropriate tools to access hatches and covers.
- Appropriate traffic control signage and procedures.
- Protective clothing and eye protection.
- Note: Entering a confined space requires appropriate safety and certification. It is generally not required for routine maintenance of the system.
- Vacuum truck (with pressure washer attachment preferred).

Maintenance Procedures

It is recommended that maintenance occurs at least three days after the most recent rain event to allow for drain down of any associated upstream detention systems. Maintaining the system while flows are still entering it will increase the time and complexity required for maintenance. Cleaning of the sump chamber can be performed from the finish surface without entry into the vault utilizing a vacuum truck. Once all safety measures have been set up cleaning of the sump chamber can proceed as followed:

- Using an extension on a vacuum truck position the hose over the opened access hatch and lower into the center of the sump chamber on the inlet side of the oil/floatables skimmer. Remove all floating debris, standing water and sediment from the sump chamber. Access to the bottom of the sump chamber is unimpeded. The vac hose can be moved from side-to-side to fully remove sediments at the corners. A power washer can be used to assist if sediments have become hardened and stuck to the walls or the floor of the chamber. Repeat the same procedure on the effluent side of the oil/floatables skimmer to remove any remaining sediment. This completes the maintenance procedure required on the sump chamber and the SciClone™ Separator.
- The last step is to close up and replace all access hatches and remove all traffic control.
- All removed debris and pollutants shall be disposed of following local and state requirements.
- Disposal requirements for recovered pollutants and spent cartridges may vary depending on local guidelines. In most areas the sediment, once dewatered, can be disposed of in a sanitary landfill. It is not anticipated that the sediment would be classified as hazardous waste.
- In the case of damaged components, replacement parts can be ordered by the manufacturer.

7. Statements

The following attached pages are signed statements from the manufacturer (Bio Clean Environmental, Inc.), the testing lab (Good Harbour Laboratories), and NJCAT. These statements are a requirement of the verification process.

In addition, it should be noted that this report has been subjected to public review (e.g. stormwater industry) and all comments and concerns have been satisfactorily addressed.



Date: 10/14/2017

To Whom It May Concern,

We are providing this letter as our statement certifying that the protocol titled "New Jersey Department of Environmental Protection Laboratory Protocol to Assess Total Suspended Solids Removal by a Hydrodynamic Sedimentation Manufactured Treatment Device" (NJDEP HDS Protocol, January 2013) has been strictly followed.

We certify that all requirements and criteria were met and/or exceeded during testing of the SciClone™ Hydrodynamic Separator.

If you have any questions please contact us at your convenience.

Sincerely,

Zachariha J. Kent
Director of Research & Development
Bio Clean, a Forterra Company.

Signature: Jack Kent Date: 10/14/2017

P O Box 869 Oceanside CA 92049
(760) 433-7640 • Fax (760) 433-3176
www.BioCleanEnvironmental.net



October 18, 2017

Dr. Richard Magee, ScD., P.E., BCEE
Executive Director
New Jersey Corporation for Advanced Technology

Re: Performance Verification of the SciClone® Hydrodynamic Separator (HDS)

Dear Dr. Magee,

Good Harbour Laboratories was contracted by BioClean Environmental Services Inc., A Forterra Company, to conduct a performance verification of their SciClone® Hydrodynamic Separator in accordance with New Jersey Department of Environmental Protection Laboratory Protocol to Assess Total Suspended Solids Removal by a Hydrodynamic Sedimentation Manufactured Treatment Device (January, 2013).

Good Harbour Laboratories is an independent hydraulic test facility located in Mississauga, Ontario Canada. I certify that we have evaluated the SciClone® HDS model SC-4 from September 11 - 21, 2017 according to the aforementioned test protocol. The results presented in the NJCAT Verification Report dated October, 2017 are accurate and all procedures and requirements stated in the test protocol were met or exceeded. Good Harbour Laboratories has no vested interest in the test results or financial conflict of interest in providing independent testing services to BioClean Environmental Services Inc.

Sincerely,

Dr. Greg Williams, PhD, P.Eng.
Managing Director
Good Harbour Laboratories



Good Harbour Laboratories
T: 905.886.7276 | F: 905.886.7279
A: 2525 Denison Drive, Mississauga, ON L4S 1L5
www.goodharbourlabs.com



**Center for Environmental Systems
Stevens Institute of Technology
One Castle Point
Hoboken, NJ 07030-0000**

November 1, 2017

Shashi Nayak
NJDEP
Division of Water Quality
Bureau of Non-Point Pollution Control
401-02B
PO Box 420
Trenton, NJ 08625-0420

Dear Mr. Nayak,

Based on my review, evaluation and assessment of the testing conducted on the SciClone™ Hydrodynamic Separator (Model SC-4) at Good Harbour Laboratories (GHL), an independent water technology testing lab based in Mississauga, Ontario Canada, the test protocol requirements contained in the “*New Jersey Laboratory Testing Protocol to Assess Total Suspended Solids Removal by a Hydrodynamic Sedimentation Manufactured Treatment Device (January 25, 2013)*” (NJDEP HDS Protocol) were met or exceeded. Specifically:

Test Sediment Feed

The mean PSD of the test sediments comply with the PSD criteria established by the NJDEP HDS protocol. The removal efficiency test sediment PSD analysis was plotted against the NJDEP removal efficiency test PSD specification. The test sediment was shown to be slightly finer than the sediment blend specified by the protocol ($<75\mu$); the test sediment d_{50} was 73 microns. The scour test sediment PSD analysis was plotted against the NJDEP scour test PSD specification and also shown to be finer than specified by the protocol.

Removal Efficiency Testing

In accordance with the NJDEP HDS Protocol, removal efficiency testing was executed on the SciClone™ (SC-4), a 4-ft. diameter commercially available unit, in order to establish the ability of the SciClone™ to remove the specified test sediment at 25%, 50%, 75%, 100% and 125% of

the target MTFR. The SC-4 demonstrated 50.03% annualized weighted solids removal as defined in the NJDEP HDS Protocol. The flow rates, feed rates and influent concentration all met the NJDEP HDS test protocol's coefficient of variance requirements and the background concentration for all five test runs never exceeded 20 mg/L (maximum of 2.5 mg/L).

Scour Testing

To demonstrate the ability of the SciClone™ to be used as an online treatment device, scour testing was conducted at 200% of the MTFR in accordance with the NJDEP HDS Protocol. The average flow rate during the online scour test was 1.4 cfs (630 gpm), which represents 200% of the MTFR (MTFR = 0.70 cfs). Background concentrations were <2.6 mg/L throughout the scour testing, which complies with the 20 mg/L maximum background concentration specified by the test protocol. Unadjusted effluent concentrations ranged from 2 mg/L to 2.9 mg/L. When adjusted for background concentrations, all effluent concentrations were <1 mg/L. These results confirm that the SC-4 did not scour at 200% MTFR and meets the criteria for online use.

Maintenance Frequency

The predicted maintenance frequency for all SciClone™ models is 96 months.

Sincerely,



Richard S. Magee, Sc.D., P.E., BCEE
Executive Director

8. References

1. NJDEP 2013. New Jersey Department of Environmental Protection Procedure for Obtaining Verification of a Stormwater Manufactured Treatment Device from New Jersey Corporation for Advanced Technology. January 25, 2013.
2. NJDEP 2013. New Jersey Department of Environmental Protection Laboratory Protocol to Assess Total Suspended Solids Removal by a Hydrodynamic Sedimentation Manufactured Treatment Device. January 25, 2013.
3. GHJ Laboratory Notebook: A017, pp. 31-42; and A018, pp. 47-98.