



State of New Jersey

DEPARTMENT OF ENVIRONMENTAL PROTECTION

Bureau of Nonpoint Pollution Control

Division of Water Quality

401-02B

Post Office Box 420

Trenton, New Jersey 08625-0420

609-633-7021 Fax: 609-777-0432

http://www.state.nj.us/dep/dwq/bnpc_home.htm

PHILIP D. MURPHY
Governor

SHEILA Y. OLIVER
Lt. Governor

CATHERINE R. MCCABE
Commissioner

October 01, 2019

Derek M. Berg
Director – Stormwater Regulatory Management - East
Contech Engineered Solutions LLC
71 US Route 1, Suite F
Scarborough, ME 04074

Re: MTD Lab Certification
Cascade Separator™
On-line Installation

TSS Removal Rate 50%

Dear Mr. Berg:

The Stormwater Management rules under N.J.A.C. 7:8-5.5(b) and 5.7(c) allow the use of manufactured treatment devices (MTDs) for compliance with the design and performance standards at N.J.A.C. 7:8-5 if the pollutant removal rates have been verified by the New Jersey Corporation for Advanced Technology (NJCAT) and have been certified by the New Jersey Department of Environmental Protection (NJDEP). Contech Engineered Solutions, LLC (Contech) has requested an MTD Laboratory Certification for the Cascade Separator™ stormwater treatment system.

The project falls under the “Procedure for Obtaining Verification of a Stormwater Manufactured Treatment Device from New Jersey Corporation for Advance Technology” dated January 25, 2013. The applicable protocol is the “New Jersey Laboratory Testing Protocol to Assess Total Suspended Solids Removal by a Hydrodynamic Sedimentation Manufactured Treatment Device” dated January 25, 2013.

NJCAT verification documents submitted to the NJDEP indicate that the requirements of the aforementioned protocol have been met or exceeded. The NJCAT letter also included a recommended certification TSS removal rate and the required maintenance plan. The NJCAT Verification Report with the Verification Appendix (dated September 2019) for this device is published online at <http://www.njcat.org/verification-process/technology-verification-database.html>.

The NJDEP certifies the use of the Cascade Separator™ stormwater treatment system at a TSS removal rate of 50% when designed, operated, and maintained in accordance with the information provided in the Verification Appendix and the following conditions:

1. The maximum treatment flow rate (MTFR) for the manufactured treatment device (MTD) is calculated using the New Jersey Water Quality Design Storm (1.25 inches in 2 hrs) in N.J.A.C. 7:8-5.5.
2. The Cascade Separator™ shall be installed using the same configuration reviewed by NJCAT and shall be sized in accordance with the criteria specified in item 6 below.
3. This Cascade Separator™ cannot be used in series with another MTD or a media filter (such as a sand filter) to achieve an enhanced removal rate for total suspended solids (TSS) removal under N.J.A.C. 7:8-5.5.
4. Additional design criteria for MTDs can be found in Chapter 9.6 of the New Jersey Stormwater Best Management Practices (NJ Stormwater BMP) Manual, which can be found online at www.njstormwater.org.
5. The maintenance plan for a site using this device shall incorporate, at a minimum, the maintenance requirements for the Cascade Separator™. A copy of the maintenance plan is attached to this certification. However, it is recommended to review the maintenance website at <https://www.conteches.com/Portals/0/Documents/Maintenance%20Guides/Cascade-Maintenance%20Guide.pdf?ver=2018-11-05-093254-300> for any changes to the maintenance requirements.
6. Sizing Requirement:

The example below demonstrates the sizing procedure for the Cascade Separator™:

Example: A 0.25-acre impervious site is to be treated to 50% TSS removal using a Cascade Separator™. The impervious site runoff (Q) based on the New Jersey Water Quality Design Storm was determined to be 0.79 cfs.

Maximum Treatment Flow Rate (MTFR) Evaluation:

The site runoff (Q) was based on the following:

time of concentration = 10 minutes

$i = 3.2$ in/hr (page 5-8, Fig. 5-3 of the NJ Stormwater BMP Manual)

$c = 0.99$ (runoff coefficient for impervious)

$Q = ciA = 0.99 \times 3.2 \times 0.25 = 0.79$ cfs

Given the site runoff is 0.79 cfs and based on Table A-1 below, the Cascade Separator™ Model CS-4 with an MTFR of 1.80 cfs would be the smallest model approved that could be used for this site to remove 50% of the TSS from the impervious area without exceeding the MTFR.

The sizing table corresponding to the available system models is noted below. Additional specifications regarding each model can be found in the Verification Appendix under Table A-1.

Table A-1 Cascade Separator™ Models and Associated MTFRs

Model	Manhole Diameter (ft)	MTFR (cfs)	50% Maximum Sediment Storage Area Volume (ft³)
CS-4	4	1.80	9.4
CS-5	5	2.81	14.7
CS-6	6	4.05	21.2
CS-8	8	7.20	37.7
CS-10	10	11.3	58.9
CS-12	12	16.2	84.8

A detailed maintenance plan is mandatory for any project with a stormwater BMP subject to the Stormwater Management rules under N.J.A.C. 7:8. The plan must include all of the items identified in the Maintenance requirements section of the Stormwater Management rules under N.J.A.C. 7:8-5.8. Such items include, but are not limited to, the list of inspection and maintenance equipment and tools, specific corrective and preventative maintenance tasks, indication of problems in the system, and training of maintenance personnel. Additional information can be found in Chapter 8: Maintenance and Retrofit of Stormwater Management Measures.

If you have any questions regarding the above information, please contact Brian Salvo of my office at (609) 633-7021.

Sincerely,



Gabriel Mahon, Chief
Bureau of Nonpoint Pollution Control

Attachment: Maintenance Plan

cc: Chron File
Richard Magee, NJCAT
Jim Murphy, NJDEP-BNPC
Vince Mazzei, NJDEP - DLUR
Brian Salvo, NJDEP - BNPC

Cascade Separator™ Inspection and Maintenance Guide



Maintenance

The Cascade Separator™ system should be inspected at regular intervals and maintained when necessary to ensure optimum performance. The rate at which the system collects sediment and debris will depend upon on-site activities and site pollutant characteristics. For example, unstable soils or heavy winter sanding will cause the sediment storage sump to fill more quickly but regular sweeping of paved surfaces will slow accumulation.

Inspection

Inspection is the key to effective maintenance and is easily performed. Pollutant transport and deposition may vary from year to year and regular inspections will help ensure that the system is cleaned out at the appropriate time. At a minimum, inspections should be performed twice per year (i.e. spring and fall). However, more frequent inspections may be necessary in climates where winter sanding operations may lead to rapid accumulations, or in equipment wash-down areas. Installations should also be inspected more frequently where excessive amounts of trash are expected.

A visual inspection should ascertain that the system components are in working order and that there are no blockages or obstructions in the inlet chamber, flumes or outlet channel. The inspection should also quantify the accumulation of hydrocarbons, trash and sediment in the system. Measuring pollutant accumulation can be done with a calibrated dipstick, tape measure or other measuring instrument. If absorbent material is used for enhanced removal of hydrocarbons, the level of discoloration of the sorbent material should also be identified during inspection. It is useful and often required as part of an operating permit to keep a record of each inspection. A simple form for doing so is provided in this Inspection and Maintenance Guide.

Access to the Cascade Separator unit is typically achieved through one manhole access cover. The opening allows for inspection and cleanout of the center chamber (cylinder) and sediment storage sump, as well as inspection of the inlet chamber and slanted skirt. For large units, multiple manhole covers allow access to the chambers and sump.

The Cascade Separator system should be cleaned before the level of sediment in the sump reaches the maximum sediment depth and/or when an appreciable level of hydrocarbons and trash has accumulated. If sorbent material is used, it must be replaced when significant discoloration has occurred. Performance may be impacted when maximum sediment storage capacity is exceeded. Contech recommends maintaining the system when sediment level reaches the 50% storage volume. The level of sediment is easily determined by measuring from finished grade down to the top of the sediment pile. To avoid underestimating the level of sediment in the chamber, the measuring device must be lowered to the top of the sediment pile carefully. Finer, silty particles at the top of the pile typically offer less resistance to the end of the rod than larger particles toward the bottom of the pile. Once this measurement is recorded, it should be compared to the as-built drawing for the unit to determine if the height of the sediment pile off the bottom of the sump floor exceeds 50% of the total height of sediment storage sump.

Cleaning

Cleaning of a Cascade Separator system should be done during dry weather conditions when no flow is entering the system. The use of a vacuum truck is generally the most effective and convenient method of removing pollutants from the system. Simply remove the manhole cover and insert the vacuum hose down through the center chamber and into the sump. The system should be completely drained down and the sump fully evacuated of sediment. The areas outside the center chamber and the slanted skirt should also be washed off if pollutant build-up exists in these areas.

In installations where the risk of petroleum spills is small, liquid contaminants may not accumulate as quickly as sediment. However, the system should be cleaned out immediately in the event of an oil or gasoline spill. Motor oil and other hydrocarbons that accumulate on a more routine basis should be removed when an appreciable layer has been captured. To remove these pollutants, it may be preferable to use absorbent pads since they are usually less expensive to dispose than the oil/water emulsion that may be created by vacuuming the oily layer. Trash and debris can be netted out to separate it from the other pollutants. Then the system should be power washed to ensure it is free of trash and debris.

Manhole covers should be securely seated following cleaning activities to prevent leakage of runoff into the system from above and to ensure proper safety precautions. Confined space entry procedures need to be followed if physical access is required. Disposal of all material removed from the Cascade Separator system must be done in accordance with local regulations. In many locations, disposal of evacuated sediments may be handled in the same manner as disposal of sediments removed from catch basins or deep sump manholes. Check your local regulations for specific requirements on disposal. If any components are damaged, replacement parts can be ordered from the manufacturer.

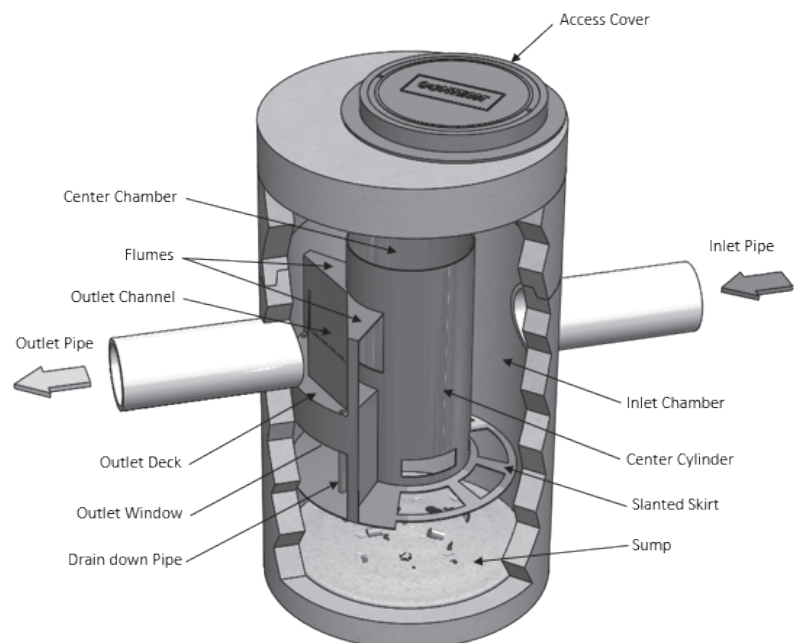

Cascade Separator Inspection & Maintenance Log

Cascade Model:		Location:			
Date	Water Depth to Sediment ¹	Floatable Layer Thickness ²	Describe Maintenance Performed	Maintenance Personnel	Comments

1. The depth to sediment is determined by taking a measurement from the manhole opening to the top of the sediment pile. Once this measurement is recorded, it should be compared to the as-built drawing for the unit to determine if the height of the sediment pile off the bottom of the sump floor exceeds 50% of the total height of sediment storage sump. Note: to avoid underestimating the volume of sediment in the chamber, the measuring device must be carefully lowered to the top of the sediment pile.
2. For optimum performance, the system should be cleaned out when the floating hydrocarbon layer accumulates to an appreciable thickness. In the event of an oil spill, the system should be cleaned immediately.



A Cascade Separator unit can be easily cleaned in less than 30 minutes.



A vacuum truck excavates pollutants from the systems.

SUPPORT

- Drawings and specifications are available at www.ContechES.com.
- Site-specific design support is available from our engineers.

©2018 Contech Engineered Solutions LLC, a QUIKRETE Company

Contech Engineered Solutions LLC provides site solutions for the civil engineering industry. Contech's portfolio includes bridges, drainage, sanitary sewer, stormwater, and earth stabilization products. For information, visit www.ContechES.com or call 800.338.1122

NOTHING IN THIS CATALOG SHOULD BE CONSTRUED AS A WARRANTY. APPLICATIONS SUGGESTED HEREIN ARE DESCRIBED ONLY TO HELP READERS MAKE THEIR OWN EVALUATIONS AND DECISIONS, AND ARE NEITHER GUARANTEES NOR WARRANTIES OF SUITABILITY FOR ANY APPLICATION. CONTECH MAKES NO WARRANTY WHATSOEVER, EXPRESS OR IMPLIED, RELATED TO THE APPLICATIONS, MATERIALS, COATINGS, OR PRODUCTS DISCUSSED HEREIN. ALL IMPLIED WARRANTIES OF MERCHANTABILITY AND ALL IMPLIED WARRANTIES OF FITNESS FOR ANY PARTICULAR PURPOSE ARE DISCLAIMED BY CONTECH. SEE CONTECH'S CONDITIONS OF SALE (AVAILABLE AT WWW.CONTECHES.COM/COS) FOR MORE INFORMATION.